

RD-71

10-bit 1080P Integrated Receiver Decoder

USER GUIDE

v2.02.24

Contents

[Contents](#)

[Application Diagrams](#)

[Rack Installation](#)

[Back Panel](#)

[DB9-M Analog audio output pinout](#)

[COM1/COM2 to DB9 Serial Adapter](#)

[GPIO and Parport information](#)

[GPIO Pinout](#)

[Parport Pinout](#)

[Front Panel Operation](#)

[Front Panel LED Indicators](#)

[Transport](#)

[Audio Decode](#)

[System](#)

[Front Panel LCD](#)

[Front Panel Button Controls](#)

[Front Panel Reset](#)

[Front Panel Menus](#)

[Services Menu](#)

[RF Rx Menu \(LB Option\)](#)

[RF Rx Menu \(PRX Option\)](#)

[IP Rx Menu](#)

[Video Menu](#)

[Audio Menu](#)

[VBI Menu](#)

[CAS Menu](#)

[IP Tx Menu](#)

[System Menu](#)

[Login](#)

[Duration](#)

[Com2](#)

[Host Name](#)

[Firmware](#)

[Feature Menu](#)

[Profile Menu](#)

[Getting Connected - Intro to Adtec User Interfaces](#)

[Web UI Interface](#)

[Ethernet Access](#)

[Zero Configuration Access](#)

[Login](#)

[Web UI Status Panel](#)

[Web UI - Input](#)

[Web UI - Profiles](#)

[Web UI - Video](#)

[Web UI - Audio](#)

[Web UI - CAS](#)

[Web UI - VBI](#)

[Web UI - TS Output](#)

[Web UI - System](#)

[Web UI - Security](#)

[Web UI - Upgrade](#)

[Web UI - Help](#)

[API Interface](#)

[SNMP Interface](#)

[RD Web UI Authentication and Security Features](#)

[Summary](#)

[Web UI Authentication Modes](#)

[Web UI Authentication Advanced mode](#)

[Other security features](#)

[HTTP Port](#)

[Stealth IP address](#)

[IP2 / GigE Management](#)

[Operational Information](#)

[DVB-S / DVB-S2 AUTO Modes](#)

[DVB-S2 - Recommended use of Pilots](#)

[Single Stream \(no restart\)-PRX only model](#)

[RF Profiles](#)

[UDP / RTP / FEC / TCP IP Rx](#)

[Multicast Reception - Address](#)

[Unicast Reception - Address](#)

[Unicast/Multicast Reception](#)

[Dolby E, Dolby D, LPCM, and Mpeg 1 Layer 2](#)

[AFD - Active Format Description](#)

[Genlock System](#)

[TS Out Decrypt](#)

[Service Filtering](#)

[Configure Service Filter on ASI](#)

[Firmware Upgrade via Web User Interface](#)

[Demodulator Firmware Upgrade via Web User Interface](#)

[In Field Feature Upgrades](#)

[Permanent Key Instructions](#)

[Temporary Key Instructions](#)

[RD-71 Zixi Setup Guide](#)

[Appendix](#)

[Appendix A - GNU General Public License](#)

[Appendix B - Technical Specifications](#)

[Base Model \(RD71-XX\)](#)

[Inputs](#)

[Outputs](#)

[Communications](#)

[Video and Audio](#)

[Physical and Operational](#)

[L-Band Demodulator \(LB option\)](#)

[DVB-S2X L-Band Demodulator \(PRX option\)](#)

[Appendix C - Adtec Digital Support & Service](#)

[Appendix D - Electrical Device Compliance Notices](#)

[Safety Warnings and Cautions](#)

[Compliance Notices](#)

[FCC](#)

[Industry Canada](#)

[European Union EMC Directive Conformance Statement](#)

[Trademarks & Copyrights](#)

Application Diagrams

At Home Production

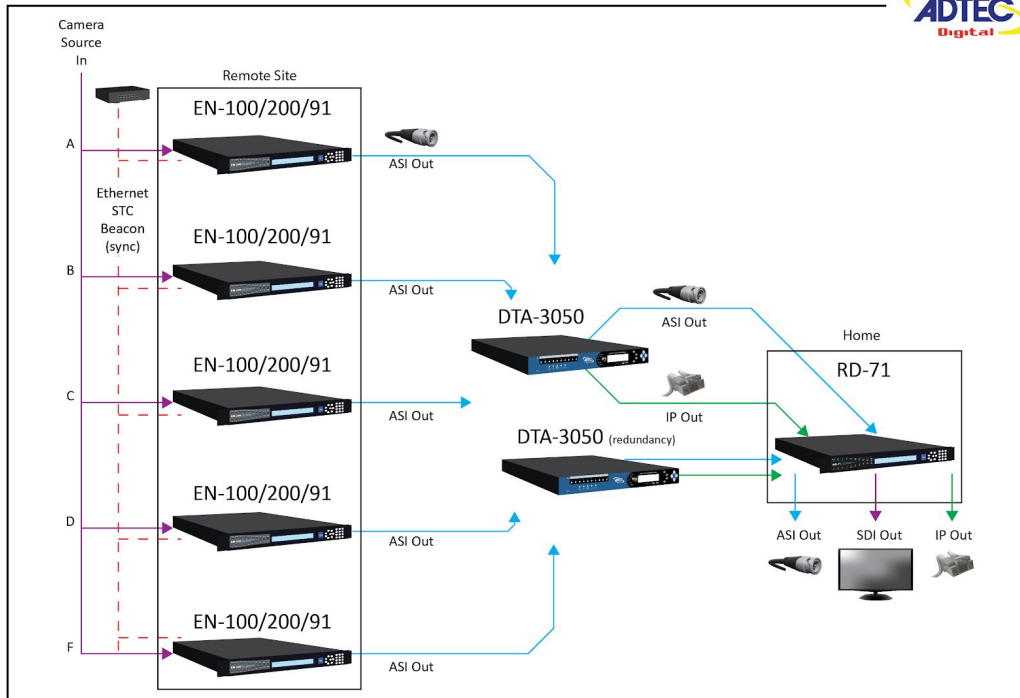

Turn-Around and Service Filtering

Service Filtering on the RD-71

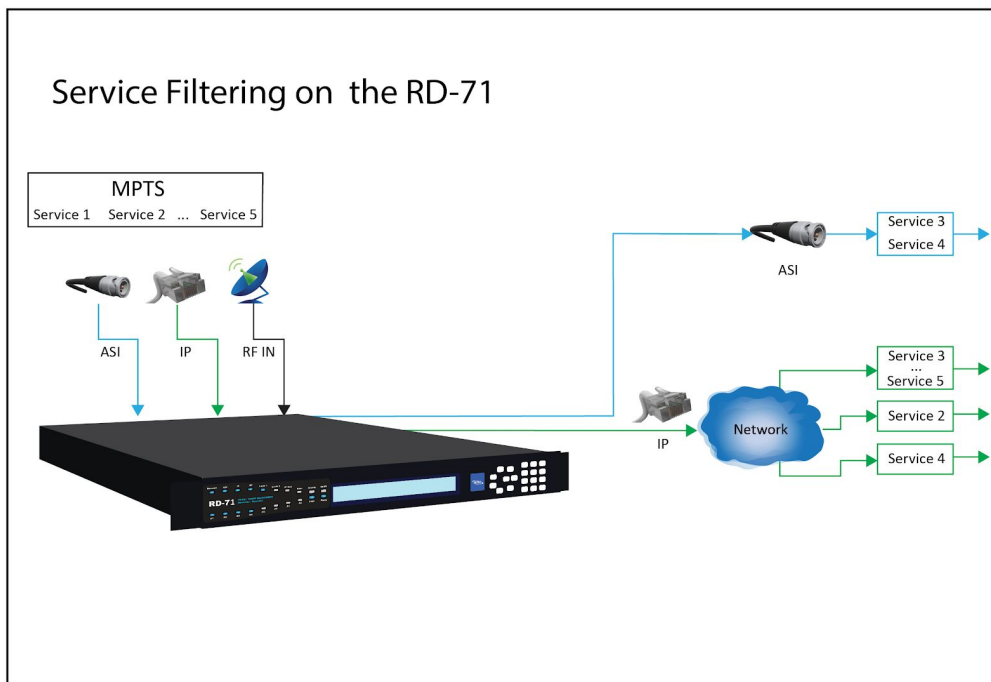

Zixi IP Transport (Zixi-Link, point to point or Zixi Receive, point to multi-point)

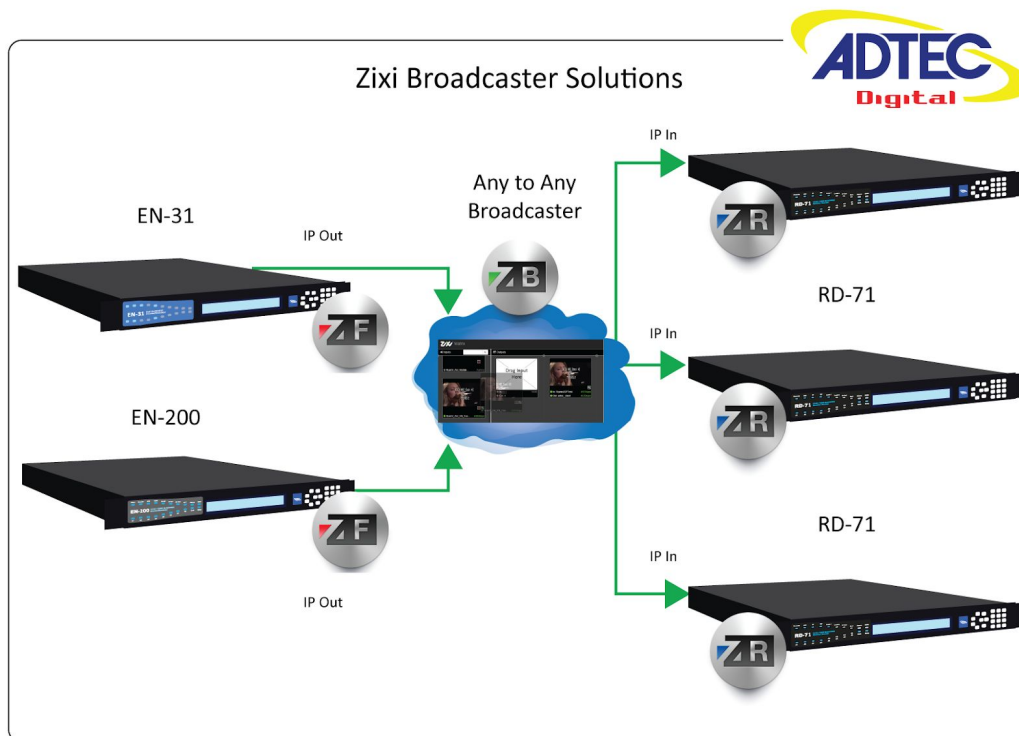
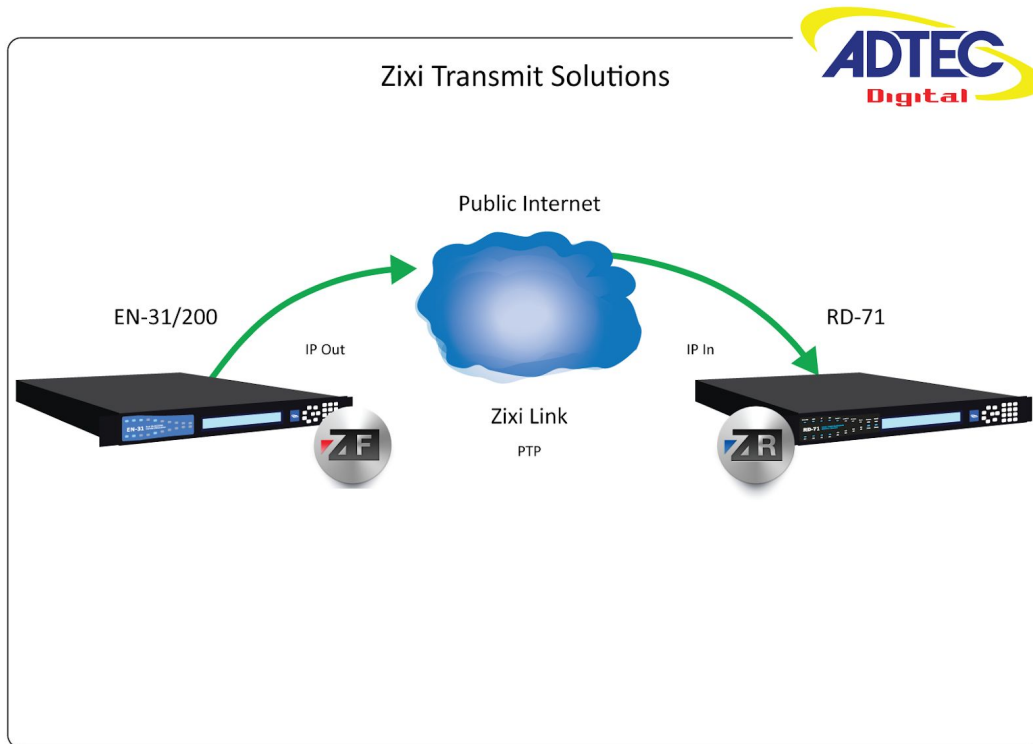

Rack Installation

The RD-71 is intended to be mounted in a standard 19" rack. It occupies 1RU of rack space and the connections are all on the rear of the unit.

To install the RD-71 into a rack use the following steps:

Step	Description
1	Determine the desired position in the rack for the RD-71 making sure that the air intake and exhausts on the sides of the unit will not be obstructed.
2	Insert the rack mount clips into place over the mounting holes in the rack.
3	Slide the RD-71 into position in the rack.
4	Secure the RD-71 to the rack by installing four rack screws through the front mounting holes and tightening.
5	If needed, secure a grounding wire use the grounding location on the rear panel of the RD-71.

Back Panel

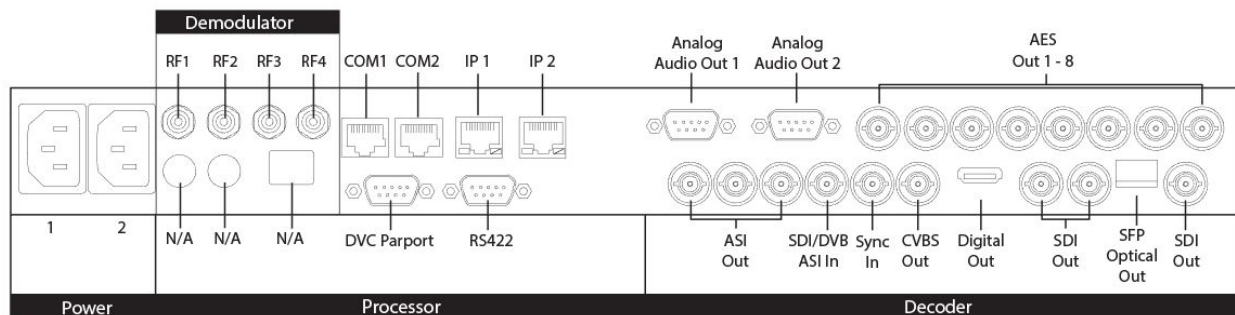

Connector	Description
Processor	
Power 1 & 2	Redundant AC Power, Standard 3 pin computer power plug (Auto range 70-240 VAC Input)
COM2	API Serial Communication Interface
COM1	Serial Port Used for Troubleshooting (Terminal)
IP 1	Default Management/Monitoring interface (10/100/1000)
IP 2	Default UDP/RTP transport interface (10/100/1000)

DVC Parport	9-pin parallel I/O interface for control systems
RS422	Not Currently Supported
Decoder	
Analog Audio Out	Balanced analog audio out. Stereo pairs 1 & 2 (600 Ohm Balanced)
AES Audio Out 1-8	x8 75 Ohm AES-3 BNC
ASI/SDI In	75 Ohm terminated BNC input. SDI input features are not active at this time.
x3 ASI OUT	x3 75 Ohm BNC ASI output per EN5000839
Sync In	Standard analog video sync separation for NTSC, PAL, 480I/P, 576I/P, 720P, and 1080I/P/PsF from Composite Video (CVBS). Bi-level & tri-level sync compatible. BNC
CVBS Out	75 Ohm BNC Standard Definition Composite Video Output
Digital Video	Digital Video Output.
SDI Out Banks	x4 Outputs from decoder: Video/Audio/VBI (SMPTE 259M-C - SD, SMPTE 292M - HD, SMPTE 424M - 3G). SDI Bank A = x2 SD/HD/3G-SDI BNC Outputs SDI Bank B = x1 SFP (for Optical SFP module) SD/HD/3G-SDI Output and x1 SD/HD/3G-SDI BNC. note*: 3G-SDI Outputs have selectable Level A and Level B Dual Link output control to retain interoperability with other third party 3G devices. The default mapping level is Level A.
Demodulator (Optional)	
RF 1 - 4	x2 or x4 RF Inputs (Demod option specific), 75 Ohm F-Connector

DB9-M Analog audio output pinout

PIN	Designation	Function
1	NC	No Connect
2	GND	Ground
3	L+	Left +
4	R+	Right +
5	GND	Ground

6	NC	No Connect
7	GND	Ground
8	L-	Left -
9	R-	Right -

COM1/COM2 to DB9 Serial Adapter

The COM1 and COM2 port is an industry standard RS-232 DTE device on RJ45/RJ48. Units ship with RJ45 to DB9 adapters that are pinned per the following.

DB9 PIN	DB9 Function	RJ45 Pin	RJ45 Function
1	Carrier Detect (CD)	2	No Connect / Carrier Detect (DCD)
2	Receive Data (RXD)	6	Transmit Data (TXD)
3	Transmit Data (TXD)	5	Receive Data (RXD)
4	Data Terminal Ready (DTR)	1	Data Set Ready (DSR)
5	Ground (GND)	4	Ground (GND)
6	Data Set Ready (DSR)	3	Data Terminal Ready (DTR)
7	Request to Send (RTS)	7	Clear to Send (CTS)
8	Clear to Send (CTS)	8	Request to Send (RTS)
9	Ring Indicator (RI)	NC / NA	No Connect / Not available on RJ45

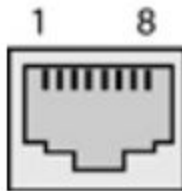

GPIO and Parport information

The GPIO port allows decoder control and TTL voltage output for monitoring systems. The GPIO feature is not enabled at this time.

The DVC Parport allows custom events to be programmed upon input pin voltage change. It contains 4 available inputs for custom commands. Please contact technical support for advanced usage in programming the parallel port.

GPIO Pinout

PIN	Designation	Function
1	NC	No Connect
2	D3	reserved for future functionality
3	D2	reserved for future functionality
4	D1	reserved for future functionality
5	D0	reserved for future functionality
6	NC	No Connect
7	5VDC	+5V DC
8	GND	ground
9	TTL Tally	reserved for future functionality

Parport Pinout

PIN	Designation	Function
1	NC	No Connect
2	D3	Data bit 3 (input)
3	D2	Data bit 2 (input)
4	D1	Data bit 1 (input)
5	D0	Data bit 0 (input)
6	NC	No Connect
7	5VDC	+5V DC
8	GND	ground
9	NC	No Connect

Front Panel Operation

The front panel LCD and keypad can be used to configure and monitor your device.



Model Indicators:



DVB-S/S2/S2X demodulator (PRX)



DVB-S/S2 demodulator (LB)



No demodulator

Front Panel LED Indicators

Transport

Indicator	Function
Decode	Off - Decoder is idle. On - Decoder is active.
ASI / IP /RF	Off - No services detected on the input. On - Services detected on the input.
Lock 1 / Lock 2	Off - Tuner is not locked On - Tuner is locked
IP Out	Off - IP Egress is idle. On - IP Egress is active.
Bars	Off - All B/T/ID options are disabled. On - B/T/ID options are enabled.

Audio Decode

Indicator	Function
A1 through A8	Off - Audio engine is not active. On - Audio engine is actively decoding or performing passthru. Blinking - Audio engine is in a failure mode (no passthru or audio decoding)

System

Indicator	Function
Alarm	Off - No system alarms. On - System alarm. (NTP or FAN alarm)
BISS	Off - Decryption configuration is turned OFF On - Decryption configuration is set to BISS1 or BISSE
Link	Off - Network communication link not detected On - Network communication link detected
Busy	Off - No network activity On - Network traffic present

Front Panel LCD

1) Feedback State: There are several quick view menu screens available when in regular feedback state. You can view any of these quick view status screens by using the up and down arrow buttons.

Decoder	Status	Input	TMR	Encryption
DECODING ASI TMR:20.000M CAS:Free to Air				
SVC: 00001 "Serv. Name" "Serv. Provider"				
Service ID		Service Name		Service Provider
CODEC	Chroma	Bit Depth	Delay Mode	
COD: H.264 CHR: 422 BITD:08 DLYM: NORMAL				
VRT: 18.012Mb/s RES:1920X1080 FR:59p				
Video Rate		Resolution		Frame Rate
Video PID	PCR PID	PMT PID	Aspect Ratio	
VID:441 PCR:441 PMT:440 ARA:16X9				
Audio 1-8	Type	Bitrate		
1:MU 384k 3:MU 384k 5:MU 384k 7:MU 384k				
2:MU 384k 4:MU 384k 6:MU 384k 8:MU 384k				
Audio PIDS 1-8				
Audio 1:11300 3:11400 5:11500 7:11600				
PIDS 2:11300 4:11400 6:11500 8:11600				
Input	Mode/FEC	Rcv Level	Link Margin	
RF1 32APSK9/10 Lvl: -52.0dB LMar:20.5dB				
LOCKED DVB-S2 Sym:29.970Ms Es/No:29.8dB				
Lock Status	Type	Symbol Rate	Eb(s)/No	
IP Rx Mode	FEC and L/D Detection	DVB per IP Packet		
IP Rx: RTP FEC: NO L/D: N/A DVBperIP: 7				
Buffer: 10% Level: 1000ms 226.0.1.58:2000				
Buffer Level (%)	Buffer Level (ms)	IP Rx Address		

2) Disabled Product State: When the product is in a disabled state, the LCD will relay the following information. To reapply network configurations simply press the Down arrow when in this state to navigate through the network menu.



Front Panel Button Controls



Using the Mode, Select, Enter, Escape, and directional buttons, the user can control the unit via the front panel.

Control	Function
Mode button	Mode will cycle through top level menus.
Select	Select will enter into menus or edit mode.
Enter	Enter submits any edited configurations.

Escape	Escape returns to the previous menu layer.
Cursor Arrows	Arrows will navigate within menus or edit configurations. <left> and <right> navigate top level or parallel menus. <up> and <down> navigate submenus. While editing a configuration <up> and <down> also moves through highlighted selections.
Programming Keypad	For value entry. F1 functions as a "+" or "-" operator. F2 functions as a "." decimal or period.

Front Panel Reset

Should you need to reset your device, you can do so via the front panel by pressing the **MODE, ESCAPE** and **RIGHT ARROW** keys simultaneously. Release all three buttons simultaneously.

Front Panel Menu

1 SERVICE MENU		
Item	Function	Options
1.1 Select Service	Allows selection of a service from a list of services per input.	ALL ASI RF1 RF2 IP
1.2 Select First	Allows you to configure the RD-71 to decode the first valid program found on any input.	ASI RF1 RF2 IP

2 RF Rx MENU (LB - IRD with Integrated Demodulator)		
Item	Function	Options
2.1 (Tuner) State	Enables or Disables RF input. note: When RF1 and RF2 are both enabled, maximum tuner performance is affected. Please view table in Appendix A for symbol rate and modcod resource limitations.	DISABLED ENABLED
2.2 Downlink (MHz)	Allows the operator to enter the satellite downlink frequency. The value for the Downlink frequency is used with the Local Oscillator frequency to calculate the L-Band frequency. The Downlink and Local Oscillator frequencies can be used to determine if spectrum inversion occurs using the following rules. If the Downlink frequency is less than the Local Oscillator frequency, then spectrum inversion does occur. If the Downlink frequency is greater than the Local Oscillator frequency, then spectrum inversion does not occur.	Range dependent upon LO configuration
2.3 Local Oscillator (MHz)	The Local Oscillator (L.O.) control specifies the frequency of the LNB local oscillator. The standard L.O. frequencies for "C" and "Ku" bands are 5150MHz and 10750MHz respectfully although, some other variants are included. If the desired L.O. frequency is not listed, select either C: Manual or Ku: Manual and enter the L.O. frequency in the Manual L.O. field.	C: 5150 KU: 11300 KU: 10750 KU: 10600 KU: 10000 KU: 9750 KU: 9600 C: MANUAL KU: MANUAL
2.4 Manual LO (MHz)	Allows manual entry of the LNB Local Oscillator frequency provided that either C: Manual or Ku: Manual is selected from the Local Oscillator pulldown menu.	
2.5 L-Band (MHz)	Allows the operator to enter the L-Band frequency within the range from 950MHz to 2.15GHz. The value entered in this field is used with the Local Oscillator frequency to calculate the Downlink frequency using the following rules. If Downlink < Local Oscillator, then Downlink - Local Oscillator = L-Band . If Downlink > Local Oscillator, then Downlink - Local Oscillator = L-Band	950MHz - 2150MHz
2.6 Acquisition Range (MHz)	Acquisition Range is defined as the range of frequencies that the tuner will scan in order to achieve carrier synchronization. Allows the operator to select the range of frequencies that the RF tuner will sweep through to acquire the carrier. e.g. If the desired carrier is at 1.080GHz and the Acquisition Range is set to 5MHz, the RF	0 - 5MHz

	tuner will sweep through 1.080GHz ± 2.5MHz to acquire the carrier.	
2.7 S2X Rolloff	S2X Rolloff will allow the tuner to operate in an optimized mode for roll-offs of 15% or less. When disabled, it will operate in standard 20% - 35% as defined by the incoming S2 BBHeader. Due to modulation manufacturers providing backwards compatibility during S2 to S2X migration, this must be manually configured for the best 5%, 10% and 15% roll-off performance.	DISABLED ENABLED
2.8 LNB Polarity	This control is primarily used in "Universal" LNB applications. The LNB Polarity control allows for LNB polarization selection; the 13VDC source will select the Vertical polarity and the 18VDC source will select the horizontal polarity. For typical "C" and "Ku" band applications, the 18 VDC option is recommended.	OFF H(18V) V(13V)
2.9 LNB Tone	This control is used only for Universal LNB applications. A universal LNB can route the high or low band from either polarity to the IRD. The high band is selected by enabling the 22 kHz tone and the low band is selected when the 0 Hz tone is enabled.	0KHz 22KHz
2.10 Modulation Type	Allows the selection of the mod type.	AUTO DVBS DVBS-2
2.11 Symbol Rate (MSym/s)	The number of symbols transmitted per second. The amount of data per symbol is dependant upon the modulation type, e.g. QPSK, 8PSK, etc. Set this field to 0 for automatic Symbol Rate.	0 = AUTO maximum value is determined by feature key.
2.12 ISI	ISI (input stream identifier) is required for multistream applications. If a multistream RF source is detected, BBHeaders containing this value will be demodulated and output to the receiver. This value has no effect during single stream applications.	0 - 255
2.13 RF Stats	General RF Lock Status is provided via the RF quickview menu, but a detailed list of further information can be found in this menu.	Scroll [UP][DOWN] to access RF status, [LEFT][RIGHT] to access (optional) RF2
2.14 PROFILE MENU		
2.14.1 Last Loaded RF Profile	Identifies current profile.	
2.14.2 Select RF1	Allows operator to review list of profiles and choose one to load/run for RF1.	

2.14.3 Select RF2	Allows operator to review list of profiles and choose one to load for RF2 (optional).	N/A for single channel
2.14.4 Save RF1	Allows operator to save the current running configuration as a profile for RF1.	
2.14.5 Save RF2	Allows operator to save the current running configuration as a profile for RF2 (optional).	N/A for single channel
2.14.6 Delete	Allows operator to delete saved profile	

2 RF Rx MENU (PRX - IRD with Integrated Demodulator)

Item	Function	Options
2.1 Tuner Input	Selects RF Input as the acquisition source.	RF1 RF2 RF3 RF4
2.2 Local Oscillator (MHz)	The Local Oscillator (L.O.) control specifies the frequency of the LNB local oscillator. The standard L.O. frequencies for "C" and "Ku" bands are 5150MHz and 10750MHz respectfully although, some other variants are included. If the desired L.O. frequency is not listed, select either C: Manual or Ku: Manual and enter the L.O. frequency in the Manual L.O. field.	C: 5150 KU: 11300 KU: 10750 KU: 10600 KU: 10000 KU: 9750 KU: 9600 C: MANUAL KU: MANUAL
2.3 Manual LO (MHz)	Allows manual entry of the LNB Local Oscillator frequency provided that either C: Manual or Ku: Manual is selected from the Local Oscillator pulldown menu.	
2.4 Downlink (MHz)	Allows the operator to enter the satellite downlink frequency. The value for the Downlink frequency is used with the Local Oscillator frequency to calculate the L-Band frequency. The Downlink and Local Oscillator frequencies can be used to determine if spectrum inversion occurs using the following rules. If the Downlink frequency is less than the Local Oscillator frequency, then spectrum inversion does occur. If the Downlink frequency is greater than the Local Oscillator frequency, then spectrum inversion does not occur.	Range dependent upon LO configuration
2.5 L-Band (MHz)	Allows the operator to enter the L-Band frequency within the range from 950MHz to 2.15GHz. The value entered in this field is used with the Local Oscillator frequency to calculate the Downlink frequency using the following rules. If Downlink < Local Oscillator, then	950MHz - 2150MHz

	Downlink - Local Oscillator = L-Band . If Downlink > Local Oscillator, then Downlink - Local Oscillator = L-Band	
2.6 Modulation Type	Selects the modulation mode being used. 'DVB-S2/DVB-S2X' locks to all S2/S2X modcods, but requires an S2X key to be selectable.	DVB-S DVB-S2 DVB-S2/DVB-S2X
2.7 Modulation Mode	Selects the modulation mode being used when in DVB-S. Note: When in DVB-S2 or DVB-S2/DVB-S2X mode, AUTO is the only valid selection. AUTO is not valid for DVB-S at this time.	AUTO QPSK_1/2 QPSK_2/3 QPSK_3/4 QPSK_5/6 QPSK_6/7 QPSK_7/8 16QAM_3/4 16QAM_7/8 8PSK_2/3 8PSK_5/6 8PSK_8/9
2.8 Symbol Rate (MSym/s)	The number of symbols transmitted per second in Msym/s. The amount of data per symbol is dependant upon the modulation type, e.g. QPSK, 8PSK, etc.	maximum value is determined by feature key.
2.9 Acquisition Range (MHz)	Acquisition Range is defined as the range of frequencies that the tuner will scan in order to achieve carrier synchronization. Allows the operator to select the range of frequencies that the RF tuner will sweep through to acquire the carrier. e.g. If the desired carrier is at 1.080GHz and the Acquisition Range is set to 5MHz, the RF tuner will sweep through 1.080GHz ± 2.5MHz to acquire the carrier.	0 - 7.5MHz
2.10 Roll-off (%)	The rolloff selection will determine the shape of the input filter. The occupied bandwidth of the modulated signal is the symbol rate multiplied by (1+α) where alpha (α) is the rolloff factor (%). By using a lower alpha, carriers can be spaced closer together on a given transponder or an increased symbol rate can be realized for a given bandwidth.	AUTO 5% 10% 15% 20% 25% 35%
2.11 ISI Control	ISI Control configures the receiver for Multistream Mode (Enabled) or Singlestream Mode (Disabled, Default). If the receiver is operating in Multistream Mode, an ISI value must be entered. **If there are any encoder/modulator rate mismatch there can be TS errors, Single Stream (no restart) should be selected**	SINGLESTREAM MULTISTREAM SINGLESTREAM (no restart)

2.12 ISI	Multistream ISI (input stream identifier) is required for multistream applications. If Multistream Mode is enabled, BBHeaders containing this value will be demodulated and output to the receiver.	0 - 255
2.13 LNB State	Enables or disables the LNB control	OFF ON
2.14 LNB Polarity	This control is primarily used in "Universal" LNB applications. The LNB Polarity control allows for LNB polarization selection; the 13VDC source will select the Vertical polarity and the 18VDC source will select the horizontal polarity. For typical "C" and "Ku" band applications, the 18 VDC option is recommended.	OFF H(18V) V(13V)
2.15 LNB Tone	This control is used only for Universal LNB applications. A universal LNB can route the high or low band from either polarity to the IRD. The high band is selected by enabling the 22 kHz tone and the low band is selected when the 0 Hz tone is enabled.	0KHz 22KHz
2.16 PLS Code	Determines Gold sequence code to use for physical layer descrambling.	0-262141
2.17 RF Stats	General RF Lock Status is provided via the RF quickview menu, but a detailed list of further information can be found in this menu.	Scroll [UP][DOWN] to access RF status, [LEFT][RIGHT] to access (optional) RF2
2.18 Profile Menu		
2.18.1 Last Loaded RF Profile	Identifies current profile.	
2.18.2 Select	Allows operator to review list of profiles and choose one to load/run.	
2.18.3 Save	Allows operator to save the current running configuration as a profile.	
2.18.4 Delete	Allows operator to delete saved profile.	

3 IP RX MENU

Item	Function	Options
3.1 Multicast Rx IP Addr	Multicast IPA sets the multicast receive Group IP address. IP Multicast receiving is supported from compatible streamers. The range of the multicast group IP is 224.XXX.XXX.XXX to 239.XXX.XXX.XXX - XXX represents any number 0 through 255. This can be either regular class A, B, C IP address or a multicast IP address.	0.0.0.0 - 255.255.255.255
3.2 Multicast Rx Port	Port number are used for receiving UDP/RTP transfers in conjunction with Multicast IPA. The valid range is 0-65535. If the port number is set to 0, then no UDP transfers will take place. 2000 is default.	0 - 65535
3.3 SSM (Source Specific Multicast) IGMPv3 Address	Configures the multicast receive Source Specific IP Address. This configuration should be configured to 0.0.0.0 (any source multicast) in most IGMPv2 multicast applications. This configuration is an advanced configuration used for redundancy, security, or IGMPv3 multicast applications. It does not function for unicast reception.	0.0.0.0 - 255.255.255.255
3.4 Multicast Connector	The multicast connector configuration determines the physical port of where the IP stream will be received, IP 1 or IP 2 ports.	IP1 IP2
3.5 Smoothing Latency (ms)	Multicast Latency sets the latency delay before the decoder begins playback from the multicast source and should be argued as a millisecond value. If the MULTICASTLATENCY delay time is too large, and the internal delay buffer is about to overflow, the system will start the multicast playback early to prevent the overflow. A log message is generated when this condition occurs.	4ms min. - max (rate dependent) 500ms (default)
3.6 Multicast Timeout (ms) (3.6 cont.)	Sets the timeout value for return to normal video playback after video multicast packets are no longer detected. The default timeout value is 300 milliseconds. If the timeout value is set too low, the multicast receive may timeout during normal reception if the packet transmission is bursty.	33 - 30000ms 300ms (default)

3.7 Multicast Error Recovery (ms)	Multicast Error Recovery sets the timeout value for recovery of multicast receive after decoder error condition is detected. The default error recovery timeout is configuration value is 10000 milliseconds.	33 - 60000ms 10000ms (default)
---	---	-----------------------------------

4 VIDEO MENU		
Item	Function	Options
4.1 OUTPUT MENU		
4.1.1 Video Loss	When video is not detected on the configured input, this setting will define the output.	<p>OFF:No video output on fault</p> <p>BLANK:Only blanking on fault</p> <p>BLANKTONES: Blanking and tones on fault</p> <p>BLANKOVERLAY: Blanking and overlay on fault</p> <p>BLANKTONESOVERLAY Blanking, tones and overlay on fault</p> <p>When a type with BLANK is selected, the current bars/matte setting will be applied.</p> <p>When a type with TONES is selected, the current tones setting will be applied.</p> <p>When a type with OVERLAY is selected, the current device name will be used.</p>
4.1.2 Fault Mode	<p>Display or Modify the current SDI video fault setting. This setting sets the video resolution when in video fault.</p> <p>This setting will be applied on startup when no video is present. If video becomes present, the setting will be overridden by the current video setting.</p>	<p>480i59.94</p> <p>576i50</p> <p>720p59.94</p> <p>720p50</p> <p>1080i59.94</p> <p>1080i50</p> <p>1080p59.94</p> <p>1080p50</p> <p>1080p29.97</p> <p>1080p25</p>
4.1.3 3G Mapping Level SDI	SDI 3G Level controls the mapping of the 3G-SDI signal when decoding 1080P50, 1080P59.94 and 1080P60 streams. The 3G-SDI signal can be mapped to Level A or Level B Dual Link. The mapping is individually configurable for each	<p>A</p> <p>B</p>

	set of outputs (SDI and SDIALT). If 3G-SDI output does not appear on the downstream device, the device may not support the currently configured mapping mode. Use SDI3GLEVEL to change the mapping mode.	
4.1.4 3G Mapping Level SDIALT	SDI 3G Level controls the mapping of the 3G-SDI signal when decoding 1080P50, 1080P59.94 and 1080P60 streams. The 3G-SDI signal can be mapped to Level A or Level B Dual Link. The mapping is individually configurable for each set of outputs (SDI and SDIALT). If 3G-SDI output does not appear on the downstream device, the device may not support the currently configured mapping mode. Use SDI3GLEVEL to change the mapping mode.	A B
4.1.5 Downscale SDI	The Downscaling SDI setting determines whether the SDI bank (SDI Output 1 and 2) will be output natively or downscaled to SD.	OFF SD
4.1.6 Downscale SDIALT	The Downscaling SDI setting determines whether the SDI bank (SDI Output 3 and 4) will be output natively or downscaled to SD.	OFF SD
4.2 Genlock Menu		
4.2.1 Genlock Mode	Configures the genlock operation of the decoder. SLAVE is primarily used for 3D applications and REMOTE is used in standard genlock operation.	OFF - Disables genlock SLAVE - Enable Genlock, Decode source is synchronous to SYNC IN signal REMOTE - Enable genlock, Decode source is NOT synchronous to SYNC IN signal
4.2.2 Horizontal Adjust	Horizontal adjustment defines the difference in the SYNC IN HSYNC and output HSYNC. Typically, this should be in the range of 0 to +1 line in clocks.	0 - 2200

	For example, a 1080I output could be adjusted from 0 to 2200.	
4.2.3 Vertical Adjust	Vertical adjustment defines the difference in the SYNC IN VSYNC and output VSYNC. Typically, this should be in the range of 0 to +1 frame in lines. For example, a 1080I output could be adjusted from 0 to 1125.	0 - 1125
4.2.4 Pixel Phase	Pixel Phase adjustment is a very fine grain adjustment that can adjust within a single clock. The increments are 1/64th of a clock. The valid range is 0 to 63.	0 - 63
4.2.5 Genlock Status	Shows if GENLOCK input is currently being used for the decoder or in FREE RUN mode	
4.2.6 Genlock CVBS Out	This configuration is used generally with 3D applications. The 'MASTER' unit CVBS configuration must be configured as 'SYNC'.	VIDEO - CVBS output is video SYNC - CVBS output is black burst sync signal
4.2.7 Genlock Reset	Reinitializes the Genlock System.	

5 AUDIO MENU

Item	Function	Options
5.1 Audio PID	Allows selection of available audio PID associated with program. note: Selection list only shows PIDs listed in PMT. Manual PID entry (such as IFB applications) is only available via the UI and SNMP at this time.	DISABLED AUTO (default) * shows PID list from actively decoding program
5.2 Offset (ms)	Adjusts each individual pairs of audio sync.	-50 - +800ms
5.3 DolbyD Mode	Configures the audio engine to Pass-through (COMPRESSED) or decode (2/0 STEREO) if a Dolby Digital AC3 PID is detected for the selected Audio input. Mpeg1Layer2 always decodes, and LPCM / Dolby E always Pass-through, regardless of this setting. Dolby Decode requires feature key capability.	PASSTHRU (default) DECODE - STEREO
5.4 DolbyE Line	This is used to configure Dolby E placement in the SDI output and is configurable per audio engine. When set to AUTO (-1), the default configuration, the Dolby E line is placed within the valid line number range for the video resolution. The Dolby E line may be manually configured to a value within range. Valid ranges for Dolby E line placement are resolution and frame rate dependent. If the configured value is not valid, the system will use the valid line used by the 'AUTO' mode. The Dolby E line status information can be used to see the actual Dolby E line placement. View Dolby E line table for more information.	-1 - 4096 -1 = AUTO

<p>5.5 SDI (Audio) Matrix</p>	<p>The SDI audio matrix allows the user to route, duplicate, or disable audio pairs within the SDI embedded output.</p>	<p>DISABLE, Disable audio output on selected SDI pair AUTO, default, Invokes automatic SDI pair assignment. This is the default setting. AUDIO1, Route Audio 1 to the selected SDI pair AUDIO2, Route Audio 2 to the selected SDI pair AUDIO3, Route Audio 3 to the selected SDI pair AUDIO4, Route Audio 4 to the selected SDI pair AUDIO5, Route Audio 5 to the selected SDI pair AUDIO6, Route Audio 6 to the selected SDI pair AUDIO7, Route Audio 7 to the selected SDI pair AUDIO8, Route Audio 8 to the selected SDI pair</p>
<p>5.6 Analog Vol. (dB)</p>	<p>Adjusts the analog volume of the first pair in dB increments</p>	<p>-49 - +18 dBu</p>
<p>5.7 Audio Sync Mode</p>	<p>Audio Sync Mode determines how the audio sub-system should behave with incoming transport streams. When it is desired for the audio subsystem to retain tight lipsync and adjust on upstream lip sync changes, this should be configured for Professional, the default setting. In rare cases, third party encoders or multiplexers may have unstable PCR/PTS timing. In these cases professional may cause intermittent drop outs as the audio sub-system attempts to retain tight lip sync. If this occurs, please change lipsync setting to Relaxed.</p>	<p>PROFESSIONAL (default) RELAXED_20_MS RELAXED_80_MS RELAXED_1_S</p>

5.8 Audio Assign Order	The RD automatically assigns audio PID's to audio engines upon stream acquisition. This setting determines if the audio assignment should be done in PID Ascending order, the Adtec default, or PMT order. Some legacy IRD's use PMT order.	PID ORDER (default) PMT ORDER
------------------------------	---	----------------------------------

6 VBI MENU		
Item	Function	Options
6.1 2038 Ancillary Passthrough	Configures the SDI ANC passthrough feature.	OFF ON
6.2 AFD Menu		
6.2.1 SDI Line Number	Configures the SDI ANC line output of AFD (SDI Output Port 1 and 2)	0 - Disabled 7 - 22
6.2.2 SDIALT Line Number	Configures the SDI Alternate ANC line output of AFD (SDI Output Port 3 and 4)	0 - Disabled 7 - 22
6.3 Caption Menu		
6.3.1 CVBS Line Number	Enables/Disables the CVBS/SD-SDI port line number for waveform closed captions.	0 - Disabled 21 - Output captions if present
6.3.2 SDI Line Number	Configures the SDI ANC line output of EIA-608/708 Closed Captions (SDI Output Port 1 and 2)	0 - Disabled 7 - 22
6.3.3 SDIALT Line Number	Configures the SDI Alternate ANC line output of EIA-608/708 Closed Captions (SDI Output Port 3 and 4)	0 - Disabled 7 - 22
6.4 Teletext Menu		
6.4.1 Waveform Teletext	Enables/Disables the CVBS/SD-SDI port line number for waveform Teletext.	0 - Disabled 22 - Output teletext if present
6.4.2 SDI Line Number	Configures the SDI ANC line output of OP47/Teletext (SDI Output Port 1 and 2)	0 - Disabled 7 - 22
6.4.3 SDIALT Line Number	Configures the SDI Alternate ANC line output of OP47/Teletext (SDI Output Port 1 and 2)	0 - Disabled 7 - 22

7 CAS MENU

Item	Function	Options
7.1 Decryption Mode	Configures the current decryption setting.	OFF BISS_1 BISS_E_USER_ID_ONE BISS_E_USER_ID_TW O
7.2 Clear Session Word	The session keys used for decryption. [MODE BISS_1] uses a 12-digit hexadecimal Clear Session Word.	user-defined using the numeric keypad
7.3 Encrypted Session Word	The 16-digit hexadecimal Encrypted Session Word for use with BISS_E modes.	user-defined using the numeric keypad
7.4 User ID One	Valid in Mode BISS_E_USER_ID_ONE ONLY. The 14-digit hexadecimal User ID (injected ID) used for decryption.	user-defined using the numeric keypad
7.5 User ID Two	Valid in Mode BISS_E_USER_ID_ONE ONLY. The 14-digit hexadecimal User ID (injected ID) used for decryption.	user-defined using the numeric keypad
7.6 TS Out Decrypt	<p>The TS Out Decrypt configuration determines if the ASI output should mirror the selected input (OFF), thus preserving any encrypted streams or if it should be decrypted / free to air (ON).</p> <p>OFF, the default configuration, is recommended for users needing to redistribute transport streams in their original form. The decoder will decrypt / decode the selected program with the entered BISS key, but the ASI output will remain unaltered.</p> <p>ON is recommended for users needing to redistribute the ASI output as a free to air SPTS/MPTS. All programs will be decrypted with the user entered BISS key.</p>	OFF ON

8 IP Tx 1 - 4

Note: this is a parallel menu. It has four indices. Use the left or right arrows to navigate to desired index.

Item	Function	Options
8.1 Mode	Enables IP Egress.	OFF SEND
8.2 IP Tx Mode		ICP UDP/RTP
8.3 Tx IP Address	The IP Address of which the Multicast or Unicast is broadcast. Multicast addressing supports the transmission of a single IP datagram to multiple receivers. Valid Multicast addressing range is 224.10.XXX.XXX to 239.XXX.XXX.XXX. Unicast addressing sends a single IP datagram to only one receiver. The Unicast address will be the unique IP of the receiving device.	user-defined; numeric field in format xxx.xxx.xxx.xxx
8.4 Tx Port	port assignment used for transmitting a multicast	user-defined using the numeric keypad
8.5 Tx Unicast Gateway (Address)	The Unicast Gateway automatically handles IP routing for unicast transmissions. This must be configured if the outgoing unicast requires a different gateway from the configured system default gateway. A route is automatically added when the unit is configured for transmit and a Unicast Gateway exists. The route is deleted if set to 0.0.0.0 or Multicast Mode set to OFF.	user-defined; numeric field in format xxx.xxx.xxx.xxx
8.6 DVB per IP	Configures the amount of DVB transport stream packets (188 bytes per DVB packet) per IP packet payload	1 4 7
8.7 RTP	allows for sequence numbering and timing	OFF (UDP) ON (RTP)
8.8 FEC Mode	Forward Edge Correction; selects on/off. When selected, sends two FEC RTP streams in addition to a source RTP stream enabling a receiver to reconstruct missing packets in the source stream.	OFF ON MAXBURST BURST LOWLATENCY

8.9 FEC L	affects the maximum burst packet loss that can be recovered Note: The product of FEC L and FEC D cannot exceed a value of 100	4-20
8.10 FEC D	defines latency involved in burst recovery	4-20
8.11 TYPE OF SERVICE	Allows the operator to sets the TOS bits in the IPv4 header of the TSoIP payload	0 = Normal service 2 = Minimize monetary cost 4 = Maximum reliability 8 = Maximize throughput 16 = Minimize delay
8.12 TTL	Time-to-Live; specifies the number of iterations or transmissions the packet can undergo before it is discarded	user-defined using the numeric keypad
8.13 Tx Connector	sets the physical connector (on the rear of the unit) to use for multicast transmit purposes on the indicated encode channel.	IP 1 IP 2

9 SYSTEM MENU

9.1 Login

Units ship with the front panel logged in by default. If you become logged out and are prompted for a password, use the following key sequence for access.

note: The key sequence can be remembered by using the word 'USER' for '**U**p, **S**elect, **E**nter, **R**ight'.

Action
Press <Select>
Press <Up> arrow
Press <Select>
Press <Enter>
Press <Right> arrow
Press <Enter>

9.2 Duration

The front panel also has a login duration feature. This setting allows the user to specify a time frame (in minutes) until the unit will automatically log itself out.

Action
Press mode until you see the System Menu.
Press <Select>
Press the <Down> arrow
Press <Select>
Using the <Up> and <Down> arrows, select the value you wish.
Press <Enter> to save your selection

Possible Configurations:

0 (Zero): The unit will not automatically log out.

1-9: The duration of time, in minutes, before the unit logs out, if no input is received.

9.3 Network Menu

Item	Function	Options
9.3.1 IP 1 Address	This is the address of your device on your network specific to the IP 1 Port.	user-defined using the numeric keypad Default is 192.168.10.48
9.3.2 IP 1 Mask	Defines the unit relative to the rest of your network.	user-defined using the numeric keypad Default is 255.255.255.0
9.3.3 IP 1 DHCP	The Dynamic Host Configuration Protocol allows your device to self-locate network IP 1 parameters.	On (finds own DHCP Address) Off (defaults to last entered IP Address) Default is OFF
9.3.4 IP 2 Address	This is the address of your device on your network specific to the IP 2 Port.	user-defined using the numeric keypad Default is 192.168.20.48
9.3.5 IP 2 Mask	Defines the unit relative to the rest of your network.	user-defined using the numeric keypad Default is 255.255.255.0
9.3.6 IP 2 DHCP	The Dynamic Host Configuration Protocol allows your device to self-locate network IP 2 parameters.	On (finds own DHCP Address) Off (defaults to last entered IP Address) Default is OFF
9.3.7 Gateway IP Address	The gateway is a routing mechanism that passes traffic between different subnets and networks.	user-defined using the numeric keypad Default is 192.168.10.1

9.3.8 Stealth IP Address	This is a security feature that allows only the designated Stealth IP Address to communicate with the unit for FTP and other services. This control allows one-point override access to the Stealth IP Address.	user-defined using the numeric keypad Default is 0.0.0.0. Using all 0s effectively turns this function off.
9.4 Time Menu		
9.4.1 Time	Defines system time	user-defined using the numeric keypad
9.4.2 Timezone	Defines the time zone the unit operates in	
9.5 NTP Menu		
9.5.1 NTP Status	Network Time Protocol SYNC status	Read-only
9.5.2 NTP IP Address	IP address designated for Network Time Protocol	user-defined using the numeric keypad Default is 0.0.0.0. Using all 0's effectively turns this function off.
9.6 Alarm Menu		
<i>Event Record</i>	<i>Log of events outside of regular operating parameters</i>	<i>scroll up and down to view log items</i>
9.7 SNMP Menu		
9.7.1 SNMP	Controls the status (ON/OFF) of the Simple Network Management Protocol (SNMP) feature. We support SNMPv2c.	OFF ON
9.7.2 Read-only community	The Simple Network Management Protocol (SNMP) Read-Only Password. Default Value: "adtec"	user-defined using the numeric keypad default: adtec

9.7.3 Read-write community	The Simple Network Management Protocol (SNMP) Read-Write Password. Default Value: "none"	user-defined using the numeric keypad default: none
9.7.4 Trap Community	The Simple Network Management Protocol (SNMP) trap community. Default Value: "public"	user-defined using the numeric keypad
9.7.5 Trap Sink	The Simple Network Management Protocol (SNMP) trap sink, destination for sending SNMP traps. Default Value: "127.0.0.1" / localhost.	user-defined using the numeric keypad
9.8 Com2 Settings	RS-232 terminal monitor for communicating with the internal host motherboard for diagnostics.	115200 8 1 NONE 57600 8 1 NONE 38400 8 1 NONE 19200 8 1 NONE 9600 8 1 NONE Default is 38400 8 1 None
9.9 FEATURE MENU		
9.9.1 Permanent ID	Shows the units unique permanent identifier. This ID is required by support when purchasing unit capability keys.	Read-Only
9.9.2 Temporary ID	Shows the units unique temporary identifier. This ID is required by support to provide temporary unit capability keys. If all 0's, your unit is not temporary key capable.	Read-Only
9.10 Host Name	The hostname of the unit. This name is be used by unit to broadcast zero-conf name and is viewable in web-browser title bar	Read-Only
9.11 Firmware	Reports the currently running firmware version of your device.	Read-Only
9.12 Backlight Dim Delay (sec)		0-255

Profile Menu

Item	Function	Options
Last Loaded Profile	Displays the last profile loaded	**
Select	The select submenu lists all stored profiles and allows loading	**
Save	The save submenu saves a profile with a user designated name	Spaces are not accepted as part of a profile name.
Delete	The delete submenu deletes a profile from the available list	**

Getting Connected - Intro to Adtec User Interfaces

Web UI Interface

A web-based control software application comes pre-installed on the RD-71.

Ethernet Access

To begin, you will need to connect to your RD-71 via Ethernet directly, or by adding the RD-71 to your local area network. The default address for all Adtec devices is 192.168.10.48.

To connect directly to the device, make sure that your computer and the device have IP addresses within the same IP class range.

(ex. 192.168.10.48 for the device and 192.168.10.49 for your computer).

If you need to change the IP address of the device, this can be done via the front panel, System > Network menu. Using a CAT 5 crossover cable, connect one end to your computer and the other to the Ethernet port found on the processor section of the back panel. (Some computers can auto negotiate the connection and a crossover may not be necessary.)

To add the device to a LAN, connect a standard CAT 5 Ethernet cable to your network router and then to the Ethernet port on the back of the device. If your network is DHCP enabled and you prefer that over a static IP, you can turn on DHCP for the device via the front panel, System > Network menu.

Zero Configuration Access

Adtec Digital has adopted zero-configuration networking technology, streamlining the setup and configuration processes for our products. The use of this technology enables automatic discovery of Adtec devices and services on an IP network. Used in tandem with the web-based control and configuration applications we can now provide 1-click access to any device.



By using the built-in Bonjour locator in Apple's Safari browser or the plug-ins readily available for IE or Firefox browsers, users can locate all of the Adtec devices on a network by referencing the serial number on the back of the device. Clicking on the unit in the Bonjour list will re-route you to a login page. If you do not wish to use Bonjour, you can reach the device's web application by pointing your browser to the IP Address of the device. Ex. <http://192.168.10.48/> .

Login

Once you reach the default login page for the web-based application, you will need to login by pressing the login button. You will be prompted for a username and password. The default username is 'adtec'. The default password is 'none'.

The left-hand panel of the application will report current status in real-time while the right panel tabs will allow you to configure your device. As you navigate through the web application look for the ? icons associated with each parameter. By clicking on these question marks, you can view additional information about how the parameter is used.

Web UI Status Panel

The left-hand panel of the web application will report current device status while the right-hand panel will allow you to configure your device. This section will cover what each part of the status panel represents. Each panel may be collapsed or expanded by clicking on the icon with the 'double up'  or 'double down'  arrows. The heading of each status may contain an LED that summarizes the current state of the individual status box. Green represents, OK, Yellow represents, Potential Warning, and Red represents an alarm.

Firmware and Temperature

<p>The top left hand status displays a logo of the product, Firmware version and operating temperature of the IRD</p>	
---	---

Decoder Status

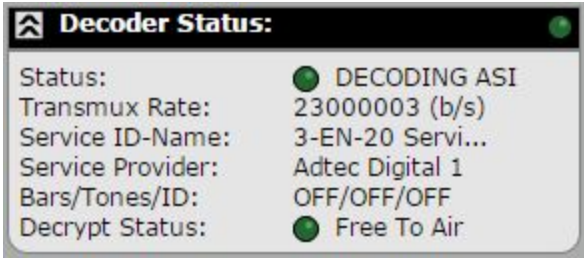
<p>The Status LED will be green if the decoder is actively decoding a program from the input. The selected input data rate (Transmux Rate) is displayed as well as the Service ID-Name (Program Number and Program Name), Service Provider, Generated Bars/Tones/ID Status and whether the program is being decrypted successfully with a BISS key.</p>	
---	--

RF Rx Status

The RF status is only available if the optional hardware demodulator is installed.

RF Status provides an indication of tuner lock along with the receive level (dBm), Eb/No or Es/No (dB), Link Margin (dB), Modulation and Coding, Symbol Rate, L-Band Frequency and Interface Rate.

The LED will be *green* if the tuner is locked, *yellow* if the tuner is disabled or *red* if the tuner is enabled and not locked. The status will read "FEA_LOCKED" and a transport stream will not come through if appropriate feature keys have not been enabled.

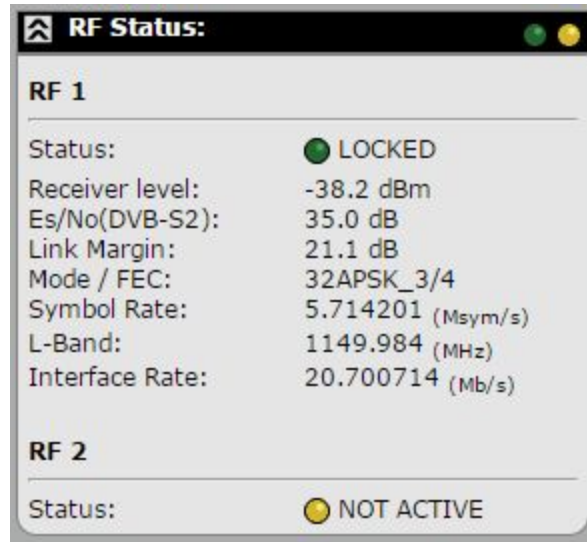

IP-Rx Status

The IP-Rx status displays information about the IP-Rx configuration. Further detailed status can be found on the Input -> IP Rx Params page.

The LED will be grey if the input is disabled, red if an input is not detected or green if a stream is detected. The current IP-Rx configuration is also displayed for average bit-rate detected, current buffer level and the protocol used for reception. The IRD automatically detects protocol and FEC parameters if enabled.

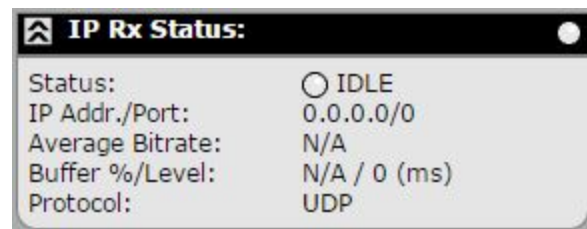

Video Status

This window shows statistics about the decoded incoming (video elementary stream) and outgoing SDI video. Video Status does not contain a colored LED for status.

Input transport stream information includes video rate (b/s), codec and chroma detection, bit-depth, resolution/frame rate, down-scaling

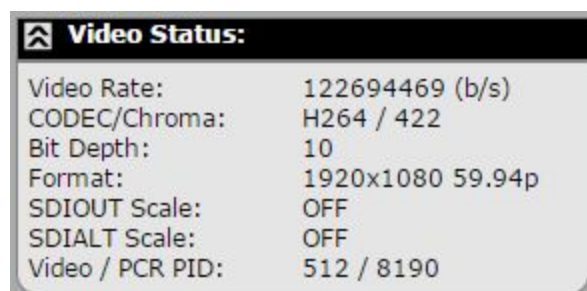

for SDI and SDI Alt and Video/PCR PID details.

Audio Status

This window shows statistics about the decoded incoming audio elementary streams.

Input transport stream information includes audio type, channel configuration, PID (decimal) and the encoded audio rate (kb/s).

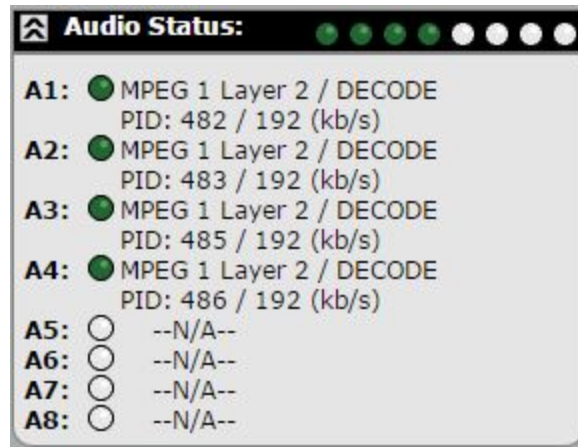

IP-Tx Status

The IP-Tx status window displays information about the IP-Tx profiles that can be configured.

Status will be green if the Tx profile is set to **ENABLED** *and* if link is detected on the configured output.

The configured IP destination parameters IP Address/Port, Source Port, Protocol and DVB TS Packets per IP Packet can be viewed in this status.

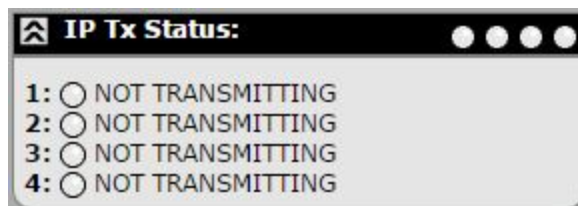

Web UI - Input

RD Services allows input and program selection for the decoder. The IRD can be configured for 'Select First Found' next to the given input (ASI, RF1, RF2, IP), a specific program if programs are detected or an 'Advanced Input' selection can be made if no services have been connected to the IRD yet.

Select First Found sorts the programs in numerical order and decodes the first 'decodable' service. If a service is encrypted and the service fails to decrypt (wrong BISS key, BISS configuration OFF or non-BISS encryption state), the next service will be attempted to be decoded. The IRD will continue attempting services until a decodable service is found. If the input fails or if a new input is detected, the first found mechanism will start over again. Outputting video is the #1 priority when in Select First Found mode. Click the radio button next to the desired input to 'Select First Found'.

The **Reset** input button can be used to clear inputs and restart the decode session. In rare cases, this may be needed if the decoder does not recover properly. The reset button will reset the decode session in a few seconds as opposed to waiting for an entire system reboot.

Manual Selection occurs when the 'SELECT' button is pressed next to a listed service. The decoder will ONLY decode the Service ID on the provided input where the SELECT button was pressed. This is "live" manual selection. Only services that are "live" are displayed in the tables. If the Service ID fails or is removed, the decoder will stop and fall to the fault mode state as configured on the Video Output tab. The decoder will resume once the Service ID is returned to a valid state.

Advanced Input is available for operators who want to pre-configure the Input and Service ID when the Service ID does not exist. The advanced input is available for "non-live" services. When Service Number "-1" is entered, the unit will be in "Select First Found" mode.

RD Services | RF Params | IP Params | Bars Tones & ID

Advanced Input Sel.

ASI Reset <input type="radio"/> Select first found				
Select	Service ID	Service Name	Service Provider	Details
-- No Services Found --				

RF1 Reset <input checked="" type="radio"/> Select first found				
Select	Service ID	Service Name	Service Provider	Details
Current	1	EN100 5	Adtec Digital	Details

RF2 Reset <input type="radio"/> Select first found				
Select	Service ID	Service Name	Service Provider	Details
-- No Services Found --				

IP Reset <input type="radio"/> Select first found				
Select	Service ID	Service Name	Service Provider	Details
-- No Services Found --				

Advanced Input Selection ✕

Primary Input:

Service Number:

Apply

RF Params (LB model)

RD Services	RF Params	IP Params	Bars Tones & ID
-------------	-----------	-----------	-----------------

Apply **Cancel**

Select Profile:

Tuner 1: **Create RF Profile**

State:

Downlink(MHz):

Local Oscillator(MHz):

Manual LO(MHz):

L-Band(MHz):

LNB 1:

Voltage:

Tone:

Advanced Configuration

Acquisition Range:

S2X Rolloff:

Demodulator 1:

Type:

Symbol Rate(Msym/s):

ISI:

PLS Mode:

PLS Code 1:

PLS Code 2:

Advanced Status

Manage RF Profiles

X ▼

Select Profile:

Tuner 2: **Create RF Profile**

State:

Downlink(MHz):

Local Oscillator(MHz):

Manual LO(MHz):

L-Band(MHz):

LNB 2:

Voltage:

Tone:

Acquisition Range:

S2X Rolloff:

Demodulator 2:

Type:

Symbol Rate(Msym/s):

ISI:

PLS Mode:

PLS Code 1:

PLS Code 2:

RF Params allows user to Manage RF Profiles - See [RF Profiles](#), configure RF tuner parameters and see advanced tuner status.

State - Enables or Disables the RF Input.

Note: When RF1 and RF2 are both enabled, maximum tuner performance is affected. If this condition occurs, please disable one of the RF inputs. Please view [tuner specifications](#) for

symbol rate and modcod resource limitations.

Downlink - Allows the operator to enter the satellite downlink frequency. The value for the Downlink frequency is used with the Local Oscillator frequency to calculate the L-Band frequency. $L\text{-Band} = \text{absoluteValue}(\text{Downlink} - \text{LO})$.

Local Oscillator - The Local Oscillator (L.O.) control specifies the frequency of the LNB local oscillator. The standard L.O. frequencies for "C" and "Ku" bands are 5150MHz and 10750MHz respectively although, some other variants are included. If the desired L.O. frequency is not listed, select either C: Manual or Ku: Manual and enter the L.O. frequency in the Manual L.O. field.

Manual LO - Allows manual entry of the LNB Local Oscillator frequency provided that either C: Manual or Ku: Manual is selected from the Local Oscillator pulldown menu.

L-Band - Allows the operator to enter the L-Band frequency within the range from 950MHz to 2.15GHz. The value entered in this field is used with the Local Oscillator frequency to calculate the Downlink frequency using the following rules. If $\text{Downlink} < \text{Local Oscillator}$, then $\text{Downlink} - \text{Local Oscillator} = |L\text{-Band}|$. If $\text{Downlink} > \text{Local Oscillator}$, then $\text{Downlink} - \text{Local Oscillator} = L\text{-Band}$.

LNB Voltage - This control is primarily used in "Universal" LNB applications. The LNB Polarity control allows for LNB polarization selection; the 13VDC source will select the Vertical polarity and the 18VDC source will select the horizontal polarity. For typical "C" and "Ku" band applications, the 18 VDC option is recommended.

LNB 22kHz Tone - This control is used only for Universal LNB applications. A universal LNB can route the high or low band from either polarity to the IRD. The high band is selected by enabling the 22 kHz tone and the low band is selected when the 0 Hz tone is enabled.

Advanced Configuration - The advanced configuration section is not automatically displayed unless manual settings have been set, ie. symbol rate or DVB Type. Click the 'double down' arrow  to manually configure additional parameters.

Acquisition Range - Acquisition Range is defined as the range of frequencies that the tuner will scan in order to achieve carrier synchronization. This will allow the operator to select the range of frequencies that the RF tuner will sweep through to acquire the carrier. Valid Range: 0.5 - 5MHz.

S2X Roll-off - S2X Rolloff will allow the tuner to operate in an optimized mode for roll-offs of 15% or less. When disabled, it will operate in standard 20% - 35% as defined by the incoming S2 BBHeader. Due to modulation manufacturers providing backwards compatibility during S2 to S2X migration, this must be manually configured for the best 5%, 10% and 15% roll-off performance. Advanced Status will still show 20% as it is inserted into the baseband header by the modulator.

Type - Type Allows the selection of DVB-S or DVB-S2 Demodulation Type. If AUTO is

selected, the tuner/demodulator will determine the actual modulation type.

Symbol Rate Mode - Symbol Rate is defined for digital communications as the number of symbols per second. The amount of data per symbol depends on the modulation type and FEC code rate. Units for this field are expressed in MSym/s and the actual range is determined by feature key. If zero [0] or AUTO is entered, the tuner/demodulator will determine the actual symbol rate.

ISI - ISI (input stream identifier) is required for multistream applications. If a multistream RF source is detected, BBHeaders containing this value will be demodulated and output to the receiver. This value has no effect during single stream applications.

PLS Mode - PLS Mode determines the Gold sequence code to use for descrambling. DEFAULT (or 0), CODE1 (User entered sequence in 'PLS Code 1') or CODE2 (User entered sequence in 'PLS Code 2')

PLS Code 1 - User defined PLS Gold sequence code, active when PLS Mode set to 'CODE1'.

PLS Code 2 - User defined PLS Gold sequence code, active when PLS Mode set to 'CODE2'.

RF Params (PRX model)

Input	Video	Audio	CAS	VBI	TS Output	System	Security	Upgrade	Help
RD Services	RF Params	IP Params	Bars Tones & ID						

Apply
Cancel

Select Profile: ⓘ ▼ ⏴ ⏵ ⓧ Create RF Profile

Modulator Key Description: DVB-S1 + DVB-S2 + DVB-S2X + QPSK + 8-PSK + 16-QAM/16APSK + 32APSK + 64APSK + Symbol Rate 60 MBaud

Tuner:

Active Input: ⓘ	<input type="text" value="RF 1"/> ▼	Manual LO(MHz): ⓘ	<input type="text" value="18534"/>
Local Oscillator(MHz): ⓘ	<input type="text" value="KU: MANUAL"/> ▼	L-Band(MHz): ⓘ	<input type="text" value="1750"/>
Downlink(MHz): ⓘ	<input type="text" value="20284"/>	Acq. Range(MHz): ⓘ	<input type="text" value="1"/>

Demodulator:

Type: ⓘ	<input type="text" value="DVB-S2 / S2X"/> ▼	Symbol Rate(Msym/s): ⓘ	<input type="text" value="23.56"/>
Mode: ⓘ	<input type="text" value="AUTO"/> ▼	Rolloff: ⓘ	<input type="text" value="AUTO"/> ▼
Multistream Mode: ⓘ	<input type="text" value="Single Stream"/> ▼	Multistream ISI: ⓘ	<input type="text" value="30"/>
		PLS Code: ⓘ	<input type="text" value="0"/>

LNB:

State: ⓘ	<input type="text" value="DISABLE"/> ▼	Polarity: ⓘ	<input type="text" value="OFF"/> ▼
Tone: ⓘ	<input type="text" value="0 KHz"/> ▼		

Active Input - Active Input determines which RF Input should be actively tuning/demodulating with the supplied parameters.

Manual LO - Allows manual entry of the LNB Local Oscillator frequency provided that either C: Manual or Ku: Manual is selected from the Local Oscillator pulldown menu.

Local Oscillator - The Local Oscillator (L.O.) control specifies the frequency of the LNB local oscillator. The standard L.O. frequencies for "C" and "Ku" bands are 5150MHz and 10750MHz respectfully although, some other variants are included. If the desired L.O. frequency is not listed, select either C: Manual or Ku: Manual and enter the L.O. frequency in the Manual L.O. field.

L-Band - Allows the operator to enter the L-Band frequency within the range from 950MHz to 2.15GHz. The value entered in this field is used with the Local Oscillator frequency to calculate the Downlink frequency using the following rules. If Downlink < Local Oscillator, then Downlink - Local Oscillator = | L-Band | . If Downlink > Local Oscillator, then Downlink - Local Oscillator = L-Band

Downlink - Allows the operator to enter the satellite downlink frequency. The value for the Downlink frequency is used with the Local Oscillator frequency to calculate the L-Band frequency.

Acquisition Range - *Acquisition Range* is defined as the range of frequencies that the tuner will scan in order to achieve carrier synchronization. Allows the operator to select the range of frequencies that the RF tuner will sweep through to acquire the carrier. e.g: If the desired carrier is at 1.080GHz and the *Acquisition Range* is set to 5MHz, the RF tuner will sweep through 1.080GHz ± 2.5MHz to acquire the carrier.

The formula for *Acquisition Range* depends on the Symbol Rate. *Carrier Acquisition Range* (peak-to-peak) is 50kHz to 7.5 MHz. If a carrier has a Symbol Rate < 5 Mbaud, then *Acquisition Range* = 1.5 x Baudrate Max. If the Symbol Rate is > 5 Mbaud the *Acquisition Range* = 7.5 MHz max.

Type - Allows the selection of DVB-S, DVB-S2 and DVB-S2X. It is recommended to use the 'DVB-S2 / DVB-S2X' mode for all S2/S2X carriers when the unit is keyed for S2X capability.

Symbol Rate - Symbol Rate is defined for digital communications as the number of symbols per second. The amount of data per symbol depends on the modulation type. Units for this field are expressed in Msym/s. The default valid range is 1-54 Msym/s. For more information, contact your Adtec Digital Sales Representative.

Mode - This control allows the operator to select the expected modulation mode and FEC code rate for DVB-S. In DVB-S2 / DVB-S2X modes, AUTO is the only valid setting.

Rolloff - The rolloff selection will determine the shape of the input filter. This is recommended to be set to AUTO. The occupied bandwidth of the modulated signal is the symbol rate multiplied by (1+?) where alpha (?) is the rolloff factor (%). By using a lower alpha, carriers can be spaced closer together on a given transponder or an increased symbol rate can be realized for a given bandwidth.

Multistream Mode - Multistream mode configures the receiver for Multistream Mode (Enabled) or Singlestream Mode (Disabled, Default). If the receiver is operating in Multistream Mode, an ISI value must be entered.

Multistream ISI - Multistream ISI (input stream identifier) is required for multistream applications. If Multistream Mode is enabled, BBHeaders containing this value will be demodulated and output to the receiver.

PLS Code - PLS Code determines the Gold sequence code to use for physical layer

descrambling. 0 is default.

LNB State - This configuration will enable or disable power on the input connector to power the LNB. If on, the user can select the voltage and tone placed on the connector via the Polarity and Tone configurations.

LNB Polarity - This control is primarily used in "Universal" LNB applications. The LNB Polarity control allows for LNB polarization selection; the 13VDC source will select the Vertical polarity and the 18VDC source will select the horizontal polarity. For typical "C" and "Ku" band applications, the 18 VDC option is recommended.

Tone - This control is used only for Universal LNB applications. A universal LNB can route the high or low band from either polarity to the IRD. The high band is selected by enabling the 22 kHz tone and the low band is selected when the 0 Hz tone is enabled.

IP Params

IP Params allow a user to configure IP Receive parameters and see detailed IP statistics.

RD Services	RF Params	IP Params	Bars Tones & ID
-------------	-----------	-----------	-----------------

Apply
Cancel

IP Rx Mode: Connector:

Address: Port:

Source Address: Latency_(ms):

Timeout_(ms): Error Recovery_(ms):

Clear

IP Statistics:

IP Rx Uptime: 0 Days, 0 Hours, 0 Minutes, 0 Seconds

Buffer Size (ms): 0 ms

Buffer Size (% / bytes): N/A / n/a bytes

DVB Per IP Packet: N/A

RTP Header Detected:	n/a	FEC Detected:	n/a
RTP Out of Order:	n/a	FEC L/D:	n/a
RTP Duplicate:	n/a	FEC Error:	n/a
RTP Lost Packet:	n/a	FEC Recovered:	n/a
RTP MaxBurst Lost:	n/a	FEC Unrecovered:	n/a

Apply
Cancel

IP Rx Mode - Selects where the receiver should automatically detect UDP/RTP/FEC streams (UDP/RTP), whether it is setup for TCP, ZIXI-Link or ZIXI Rx. The IRD needs rebooted when changing between TCP/Zixi and UDP/RTP and will be prompted via the Web interface. TCP and Zixi are not configurable via SNMP or Front Panel at this time.

Connector - Multicast Connector setting sets the physical connector (on the rear of the unit) to use for IP receive purposes. The appropriate interface will be used based on this connector setting. Currently, IP 1 (0) and IP 2 (1) connectors are supported.

Address - UDP/RTP Mode: Multicast IPA sets the multicast receive Group IP address. IP Multicast receiving is supported from compatible streamers. The range of the multicast group IP is 224.XXX.XXX.XXX to 239.XXX.XXX.XXX - Where 0 <= XXX <= 255.

Note: If a unit is receiving a unicast, the address field is ignored. A value of 0.0.0.0 can be

entered.

Address - TCP/Zixi-Link Mode: If using TCP or ZIXI-Link, point to point modes, a value of 0.0.0.0 (listening) should be entered. Stream management / transmission is done through the transmitter or Adtec encoder.

Address - Zixi Rx Mode: In Zixi Rx mode, the IRD acts as a subscribing client. This address should contain the desired IP address of a Zixi Broadcaster.

Port - Multicast Port is the number to be used for multicast/unicast streams. Set in conjunction with Multicast IPA. Range is 0 to 65535. If the port number is set to 0, then no UDP/RTP streams will be received. 0 is default.

Source Address - Configures the multicast receive Source Specific IP Address. This configuration should be configured to 0.0.0.0 (any source multicast) in most IGMPv2 multicast applications. This configuration is an advanced configuration used for redundancy, security, or IGMPv3 multicast applications. It does not function for Unicast, TCP or Zixi reception.

Latency - Multicast Latency sets the latency delay before the decoder begins playback from the multicast source and should be argued as a millisecond value. The default MULTICASTLATENCY setting is 500 milliseconds.

The maximum configurable range of the MULTICASTLATENCY is dependent upon bit rate (10MB buffer) with the floor configurable for 4ms. The accuracy of the actual latency compared to the configured latency is dependent upon the bit-rate and protocol used. The RD adjusts the IP reception rate to match the configured multicast latency setting and is more accurate in UDP/RTP reception.

Timeout - Sets the timeout value for return to normal video playback after video multicast packets are no longer detected. The default timeout value is 300 milliseconds. If the timeout value is set too low, the multicast receive may timeout during normal reception if the packet transmission is bursty.

Error Recover - Multicast Error Recovery sets the timeout value for recovery of multicast receive after decoder error condition is detected. The default error recovery timeout is configuration value is 10000 milliseconds.

IP Statistics shows advanced statistics about the received stream. IP Rx Uptime, Buffer Size and DVB Per IP statistics are shown for all IP streams (UDP, RTP or TCP). The second half of IP statistics will only populate if an RTP stream is being received. If an RTP w/ SMPTE 2022 FEC stream is detected, FEC statistics will populate.

IP Params - ZIXI Rx Mode

Channel name is the name of the channel that is desired to be streamed. This should correspond to the Broadcaster 'Stream ID'.

Client ID is a unique identifier for this unit. It is called the remote ID on the Broadcaster.

Session ID is the password for authentication to a Zixi Broadcaster. This is optional.

Latency is the time given for error correction. It is recommended that latency is set higher than 3 x Round trip time.

FEC Enabled turns on or off Forward Error Correction. Note that FEC uses additional bandwidth set by the Overhead.

FEC Content aware allocates the FEC packets based on content.

FEC Overhead is amount of FEC packets to use. This number is the percentage of your overall bitrate. For example if set to 20%, then a 5Mb stream will use 6Mb of bandwidth as 1Mb will be used for FEC.

FEC Block is the maximum time given to the FEC to correct an issue. This should not be higher than half of the Latency setting.

Zixi Receiver IP Statistics

Data Bitrate is the currently used IP rate, this can fluctuate depending on configuration and environment.

Round trip time measures how long a packet takes to travel to the broadcaster or encoder and back. This calculation is important when configuring latency and determining error correction configurations for the application.

Total Packets are how many packets have been received since the IRD started receiving.

Jitter is the variation in the delay of received packets. Larger jitter values could indicate network congestion and increases the likelihood of network issues being seen.

Packet Rate is the amount of network packets received per second.

Latency shows what the latency is set to for the service.

Out of Order shows how many packets have been received out of the sent order. This can be caused by a high jitter or packets taking different routes through the network.

Overflow shows the number of packets lost due to buffer overflow.

Dropped shows how many packets have been lost since the receiver first locked to the service.

Duplicates shows how many packets have been repeated.

Recovered Packets shows how many successful recoveries have occurred out of the total

dropped packets. In a perfect application, the recovered packets plus the FEC recovered packets should be equal to the amount of dropped packets. IE, For every dropped packet, the packet was recovered.

Non-Recovered Packets shows how many packets have been lost. If a packet is lost then it is possible that a service artifact or disruption could be seen. The severity of the artifact depends on the type of packet lost (Table, Video, Audio, NULL, etc.).

FEC Recovered shows how many dropped FEC packets have been successfully recovered.

ARQ Recovered shows how many dropped packets have been successfully recovered by ARQ.

FEC Packets shows how many FEC packets have been received.

ARQ Packets show how many ARQ packets have been received.

FEC Bitrate shows the data rate of the FEC overhead.

Duplicates shows the number of duplicate packets received via ARQ.

FEC Packet Rate shows the number of FEC packets received per second.

Requests shows the number of requests for retransmission of dropped packets made with ARQ

IP Rx Mode: ⓘ	<input type="text" value="ZIXI-Link"/>	Connector: ⓘ	<input type="text" value="IP 2"/>
<hr/>			
Address: ⓘ	<input type="text" value="0.0.0.0"/>	Port: ⓘ	<input type="text" value="9688"/>
Source Address: ⓘ	<input type="text" value="0.0.0.0"/>	Latency _(ms) : ⓘ	<input type="text" value="1000"/>
Timeout _(ms) : ⓘ	<input type="text" value="1000"/>	Error Recovery _(ms) : ⓘ	<input type="text" value="10000"/>

⏏ Zixi Receiver (ZIXI Rx Mode Only): ⓘ

Channel Name: ⓘ	<input type="text" value="ADTEC_CHANNEL"/>	Client ID: ⓘ	<input type="text" value="ADTEC_CLIENT"/>
Session ID: ⓘ	<input type="text"/>	Latency: ⓘ	<input type="text" value="100"/>
FEC Enabled: ⓘ	<input type="text" value="DISABLED"/>	FEC Content Aware: ⓘ	<input type="text" value="DISABLED"/>
FEC Overhead (%): ⓘ	<input type="text" value="20"/>	FEC Block (ms): ⓘ	<input type="text" value="50"/>

Zixi Receiver IP Statistics:

Data Bitrate:	0	Route Trip Time (ms):	0
Total Packets:	0	Jitter (ms):	0
Packet Rate (p/s):	0	Latency (ms):	0
Out of Order:	0	Overflow:	0
Dropped:	0	Duplicates:	0

Recovered Packets:	0	Non-Recovered Packets:	0
FEC Recovered:	0	ARQ Recovered:	0
FEC Packets:	0	ARQ Packets:	0
FEC Bitrate (b/s):	0	Duplicates:	0
FEC Packet Rate (b/s):	0	NULLS Stuffed:	0
Requests:	0	Late Dropped:	0
Overflow:	0		

Bars Tones and ID

Bars Tones and ID allows an operator to 'tag' the video outputs for path routing verification. The video outputs may be tagged with a combination of generated bars/color, OSD overlay and generated tones. **Note:** When an audio pair / channel is configured for Pass through operation (LPCM, Dolby E, Dolby D, etc.) internal tone generation does not function for the pass through channels.

Advanced Tones allows the operator to mute Left/Right channels or change tone frequency.

As of 2.01.XX Firmware, Bars/Tones/ID functionality has some ties to the Fault Mode configuration (Fault Mode via the Video -> Output tab). Adtec is working to break dependencies for future firmware releases.

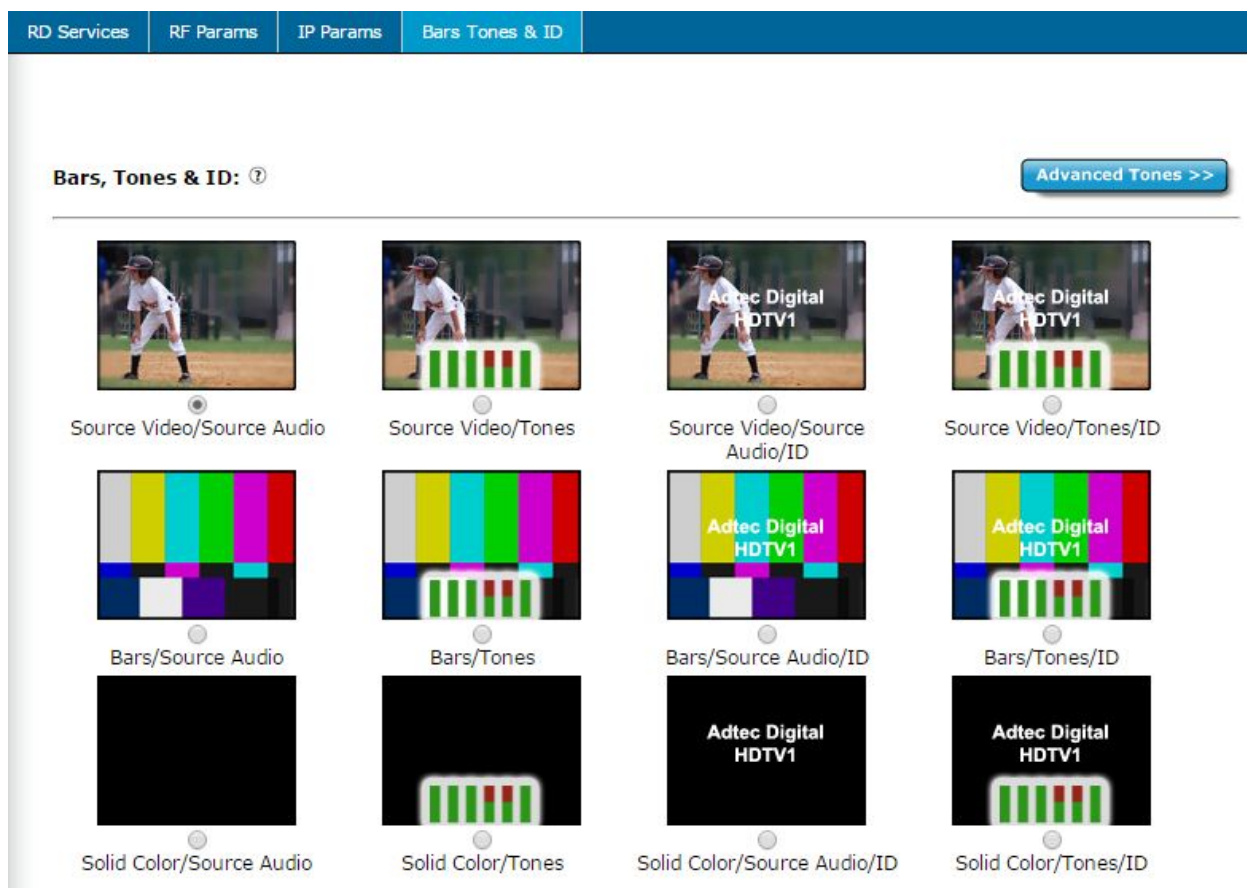

Web UI - Profiles

[Logs >>](#)
[Upload](#)
[Thumbnail](#)
[Logout X](#)

[Input](#)
[Profile](#)
[Video](#)
[Audio](#)
[CAS](#)
[VBI](#)
[TS Output](#)
[System](#)
[Security](#)
[Upgrade](#)
[Help](#)

Profiles: [?](#)
[Create NEW](#)
[^ Upload](#)

Profile Name	Load	Delete	Download
profile_12092016_162536	Load	Delete	Download
profile_12122016_141038	Load	Delete	Download
profile_12132016_152458	Load	Delete	Download

Profiles are specific to decoder settings (ex: Input, Video, Audio, CAS, IP Rx/Tx) and does not save RF demodulator configurations or System configurations at this time. RF demodulator profiles may be managed on units with demods via the RF Params tab. Loading a profile will restart the decoding process with the newly loaded configuration and will save that configuration for use upon a reboot.

Create New - Creates a new profile of the currently saved decoder state.

Load - Loads or runs the profile

Delete - Deletes the profile from the unit

Download - Downloads the profile to a local file

Web UI - Video

Genlock is used for synchronizing the SDI output to a bi-level or tri-level sync input. More can be read in the [genlock section](#).

Genlock
Output

Apply
Cancel

Genlock: ?
Genlock Reset ?

Mode: ?

Horizontal Adjust: ?

Pixel Phase: ?

CVBS: ?

Vertical Adjust: ?

Status:

STATE:	FREE RUN	SYNC SEP FORMAT:	NO_REF
REF VIDEO STANDARD:	525_29_I	OUT VIDEO STANDARD:	1080_59_P
VALID CROSS REF:	TRUE	REF LOCKED:	FALSE
DEC STATUS:	STOPPED	LOCK LOST COUNT:	0
REF LOST COUNT:	0	VIDEO SKIP COUNT:	0
VIDEO REPEAT COUNT:	0		

Apply
Cancel

Mode - Configures whether Genlock should be in FREE RUN mode (OFF) or if it should lock to the incoming source (REMOTE). The Slave configuration disables audio SRCs and is to be used for special genlock applications.

CVBS - Sets the Composite/CVBS output. When set to VIDEO CVBS output is video, when set to SYNC, CVBS output is black burst sync signal. SYNC is recommended if used as a master unit in special genlock applications (3D, UltraHD, Synchronous playback).

Horizontal Adjust - Horizontal adjustment defines the difference in the SYNC IN HSYNC and output HSYNC. Typically, this should be in the range of 0 to +1 line in clocks. For example, a 1080I output could be adjusted from 0 to 2200. Negative values can be entered.

Vertical Adjust - Vertical adjustment defines the difference in the SYNC IN VSYNC and output VSYNC. Typically, this should be in the range of 0 to +1 frame in lines. For example, a 1080I output could be adjusted from 0 to 1125. Negative values can be entered.

Pixel Phase - Pixel Phase adjustment is a very fine grain adjustment that can adjust within a single clock. The increments are 1/64th of a clock. The valid range is 0 to 63.

Genlock Status shows the state of the Genlock system.

Video Output is used for configuring the video outputs.

Genlock Output

Apply Cancel

3G-SDI Mapping Level

SDI Output: ? Level A ▼ SDI Alt Output: ? Level A ▼

Down Scaling

SDI Output: ? OFF ▼ SDI Alt Output: ? OFF ▼

Fault Configuration

Fault Mode: ? 480I59.94 ▼ On Video Loss: ? BARS, TONES & SRV ID ▼

OSD

Mode: ? OFF ▼ Output: ? SDI & SDIALT ▼

OSD Service

Service Mode: ? OFF ▼ Service Lines: ? Service Provider ▼

Service Blink: ? Line 3 only ▼

Apply Cancel

3G-SDI Mapping Level - SDI 3G Level controls the mapping of the 3G-SDI signal when decoding 1080P50, 1080P59.94 and 1080P60 streams. The 3G-SDI signal can be mapped to Level A or Level B Dual Link. The mapping is individually configurable for each set of outputs (SDI and SDIALT). If 3G-SDI output does not appear on the downstream device, the device may not support the currently configured mapping mode. Use SDI3GLEVEL to change the mapping mode.

Down Scaling - The SDI out scale configuration controls the format of the SDI output banks, SDI and SDIALT. Each bank has a unique configuration allowing simultaneous HD and SD output. When set to OFF, the native resolution is output. When set to SD, the output

is down-scaled dependent upon the source format. If the source format is 50Hz, the output will be down-scaled to PAL (720x576@50Hz). If the source format is 59.94 Hz, the output will be down-scaled to NTSC (720x480@59.94Hz). Please note that there will be a 1 frame delay in the down-scaled output. Audio synchronization is accounted for automatically on scaled outputs.

Fault Mode - Display or Modify the current SDI video fault setting. This setting sets the video resolution when in video fault. This setting will be applied on startup when no video is present. If video becomes present, the setting will be overridden by the current video setting. 1080P extended options are available when BIF shows BIXX (BI02, BI10). No feature key is required for this setting

Fault On Video Loss - In video fault, this will define the display.

STOP DECODING	Sets RVD to <i>STOP</i> .
BLACK	Sets RVD to <i>BLANK</i> , and the color bar generator to <i>BLACK</i> .
BARS	Sets RVD to <i>BLANK</i> , and the color bar generator to <i>BARS</i> .
BARS & TONES	Sets RVD to <i>BLANKTONES</i> , and the color bar generator to <i>BARS</i> .
BARS, TONES & SRV ID	Sets RVD to <i>BLANKTONESOVERLAY</i> , and the color bar generator to <i>BARS</i> .
HOLD LAST FRAME: STOP DECODING	Video output will stop at boot time and will hold last frame of video and output no audio on signal loss.
HOLD LAST FRAME: BLACK	Video output will be black with no audio at boot time and will hold last frame of video and output no audio on signal loss.
HOLD LAST FRAME: BARS	Video output will be color bars with no audio at boot time and will hold last frame of video and output no audio on signal loss.
HOLD LAST FRAME: BARS & TONES	Video output will be color bars with audio tones at boot time and will hold last frame of video and output no audio on signal loss.
HOLD LAST FRAME: BARS & SRV ID	Video output will be bars with audio and device name overlay at boot time and will hold last frame of video and output no audio on signal loss.
HOLD LAST FRAME: BAR, TONES and SRV ID	Video output will be bars with audio and device name overlay at boot time and will hold last frame of video and output no audio on signal loss.

If the "--" option is displayed when loading this tab, one of the current configuration settings is not supported. We suggest selecting a different option to properly configure your device.

OSD Mode - Controls the mode of the entire OSD engine (ON/OFF).

OSD Output - Select where the OSD output will be displayed. Options are SDI, SDIALT, both, and none. The Digital Video and CVBS video outputs mirror SDI output (with the exception of Genlock -> CVBS Control, CVBS can be set to black).

OSD Service Mode - Enables/Disables the OSD Service.

OSD Service Lines - Defines what is displayed on the OSD services command. The format of the display is below:

- (1) Service Name
- (2) Service Provider
- (3) Input
- (4) TMR

For example a value of 3 will display lines 1-3. A value of 2 will display lines 1-2. These lines can not be selected individually.

OSD Service Blink - Blink is used as a bit defined field. When used with the string command it will blink the entire string not individual lines or characters. For example, binary number 1010 will blink the 2nd and 4th line of the services command.

Web UI - Audio

Audio allows users to manually configure audio PIDs, adjust PID order, lipsync, dolby and audio sync settings. A user will be able to configure and control 8 audio PIDs if the AUD-EXT key is enabled.

Audio	SDI Matrix
<div style="display: flex; justify-content: space-between;"> Apply Cancel </div>	
<hr/> <p>Global Configurations</p>	
Audio Assign Order: ? <input type="text" value="PIDASCENDING"/> Audio Sync Mode: ? <input type="text" value="PROFESSIONAL"/>	
<hr/> <p>Audio 1</p>	
PID: ? <input type="text"/> <input type="text" value="AUTO"/> Offset _(ms) : ? <input type="text" value="0"/> Volume: ? <input type="text" value="18"/>	
Dolby Digital Mode: ? <input type="text" value="PASSTHRU"/> Dolby E Line: ? <input type="text" value="AUTO"/>	
<hr/> <p>Audio 2</p>	
PID: ? <input type="text"/> <input type="text" value="AUTO"/> Offset _(ms) : ? <input type="text" value="0"/> Volume: ? <input type="text" value="18"/>	
Dolby Digital Mode: ? <input type="text" value="PASSTHRU"/> Dolby E Line: ? <input type="text" value="AUTO"/>	
<hr/> <p>Audio 3</p>	
PID: ? <input type="text"/> <input type="text" value="AUTO"/> Offset _(ms) : ? <input type="text" value="0"/>	
Dolby Digital Mode: ? <input type="text" value="PASSTHRU"/> Dolby E Line: ? <input type="text" value="AUTO"/>	
<hr/> <p>Audio 4</p>	
PID: ? <input type="text"/> <input type="text" value="AUTO"/> Offset _(ms) : ? <input type="text" value="0"/>	
Dolby Digital Mode: ? <input type="text" value="PASSTHRU"/> Dolby E Line: ? <input type="text" value="AUTO"/>	
<hr/> <div style="display: flex; justify-content: space-between;"> Apply Cancel </div>	

Audio Assign Order - The RD automatically assigns audio PID's to audio engines upon stream acquisition. This setting determines if the audio assignment should be done in PID Ascending order, the Adtec default, or PMT order. Some legacy IRD's use PMT order.

Audio Sync Mode - Audio Sync Mode determines how the audio sub-system should behave with incoming transport streams. When it is desired for the audio subsystem to retain tight lipsync and adjust on upstream lip sync changes, this should be configured for Professional, the default setting. In rare cases, third party encoders or multiplexers may have unstable PCR/PTS timing. In these cases professional may cause intermittent drop outs as the audio sub-system attempts to retain tight lip sync. If this occurs, please change lipsync setting to Relaxed.

Audio

PID - Sets the PID for the given audio decoder. You can select one option from the list provided, or enter it manually. If entering the PID value manually, use decimal format.

Valid ranges (inclusive):

32 - 8191 Valid Decimal range

0 Used to disable the audio decoder

65535 Used to set the DEFAULT PID (First Found).

NOTE: No more than four passthru PID's are supported at this time. Hexadecimal values may be entered when in manual mode, but must be prepended with 0x. IE. '0x157E' and '5502' are both valid manual entries.

Offset - Adjust the audio sync offset for a given pair index with a millisecond offset value.

Volume - Adjusts the value of the analog volume in dB increments. The volume will attenuate, amplify or mute the audio. The valid range is -40 db to +18 dBu in ANALOG mode.

Dolby Digital Mode - Sets the Dolby Digital AC3 Output format.

--	Invalid Output Format
0 - PASSTHRU	[compressed] (default)
2 - DECODE STEREO	[2/0]

NOTE: If not set to PASSTHRU and the output mode does not equal the bitstream audio coding mode (acmod), then the decoder will perform downmixing or fill channels with zero values to meet the desired output configuration.

Dolby E Line - This is used to configure Dolby E placement in the SDI output and is configurable per audio engine. When set to AUTO (-1), the default configuration, the Dolby E line is placed within the valid line number range for the video resolution. The Dolby E line may be manually configured to a value within range. Valid ranges for Dolby E line placement are resolution and frame rate dependent. If the configured value is not valid, the system will use the valid line used by the 'AUTO' mode as per the [Dolby table](#). The Dolby E line status information (in status panel) can be used to see the actual Dolby E line placement.

SDI Audio Matrix allows any of the eight pairs of audio originating from the decoder to be routed to any of the eight audio outputs on the SDI interface. The matrix also allows the placement of Passthru audio on any of the 8 SDI output pairs. This enables the customization of the audio channel mappings from their default configuration.

NOTE: SDI Audio Matrix can be used for audio duplication.

'. It contains eight rows, each with a label like 'Pair 1 (CH 1/2):' and a dropdown menu currently set to 'AUTO'. At the bottom are another 'Apply' and 'Cancel' buttons."/>

Audio SDI Matrix

Apply Cancel

SDI Audio Mapping ? Auto:

Pair 1 (CH 1/2):	AUTO ▼
Pair 2 (CH 3/4):	AUTO ▼
Pair 3 (CH 5/6):	AUTO ▼
Pair 4 (CH 7/8):	AUTO ▼
Pair 5 (CH 9/10):	AUTO ▼
Pair 6 (CH 11/12):	AUTO ▼
Pair 7 (CH 13/14):	AUTO ▼
Pair 8 (CH 15/16):	AUTO ▼

Apply Cancel

Web UI - CAS

CAS allows an operator to configure BISS decryption and TS output configurations. Read more in the [TS Out Decryption](#) section.

Input	Video	Audio	CAS	VBI	TS Output	System	Security	Upgrade	Help
-------	-------	-------	------------	-----	-----------	--------	----------	---------	------

Conditional Access

Mode: ?

Clear Session Word: ?

Injected ID - Modification of this field with invalid data will cause decryption to fail.

User ID: ?

Transport Stream Output

TS Out Decrypt: ?

Mode - CAS Mode determines which form of Basic Interoperable Scrambling System (BISS) decryption is used.

[OFF] Disable decryption.

[BISS_1] uses the Clear Session Word only to decrypt the transmission stream.

[BISS_E_XXX] uses an Encrypted Session Word along with a User ID XXX to decrypt the transmission stream.

Clear Session Word - The session keys used for decryption.

[MODE BISS_1] uses a 12-digit hexadecimal Clear Session Word.

[MODE BISS_E_XXX] uses a 16-digit hexadecimal Encrypted Session Word.

Encrypted Session Word - [MODE BISS_E_XXX] uses a 16-digit hexadecimal Encrypted Session Word.

User ID One - Valid in [MODE BISS_E_ONE] ONLY. The 14-digit hexadecimal User ID used for decryption.

User ID Two - Valid in [MODE BISS_E_TWO] ONLY. The 14-digit hexadecimal User ID used

for decryption.

TS Out Decrypt - The TS Out Decrypt configuration determines if the ASI output should mirror the selected input (*OFF*), thus preserving any encrypted streams or if it should be decrypted / free to air (*ON*).

OFF, the default configuration, is recommended for users needing to redistribute transport streams in their original form. The decoder will decrypt / decode the selected program with the entered BISS key, but the ASI output will remain unaltered.

ON is recommended for users needing to redistribute the ASI output as a free to air SPTS/MPTS. All programs will be decrypted with the user entered BISS key.

The RD does not support BISS encrypted streams over 120Mb/s at this time. If an entire MPTS needs to be decrypted (TS Out Decrypt=*ON*), the rate must not exceed 120Mb/s. If an encrypted MPTS exceeds the 120Mb/s limit, turn TS Out Decrypt to *OFF*, the default configuration. In this mode, the selected program will be decrypted and decoded. A single encrypted program (Video+Audio) must not exceed 120Mb/s when TS Out Decrypt=*OFF*.

Web UI - VBI

Input	Video	Audio	CAS	VBI	TS Output	System	Security	Upgrade	Help
-------	-------	-------	-----	-----	-----------	--------	----------	---------	------

Apply
Cancel

Closed Captions ?

Active:

CVBS Line Number:

SDI Line Number:

SDI Alt Line Number:

Teletext ?

CVBS Line Number:

SDI Line Number:

SDI Alt Line Number:

VITC ?

SDI Line Number:

SDI Alt Line Number:

AFD ?

SDI Line Number:

SDI Alt Line Number:

Timecode Configuration ?

Source:

SDI Output:

SDI Alt Output:

SMPTE 2038 ?

2038 Passthru:

Apply
Cancel

VBI Stats

SDI				
Type	Line	DID/SDID	Present	More
captions	11	0x0000	FALSE	Count: 0
afd	11	0x0000	FALSE	Code: 0x00 AR Flag: 0
vitc		0x0000	FALSE	PID: 0x0000

Closed Captions - Captions are supported on CVBS, SDI, and SDIALT. To enable waveform captions on CVBS and SD-SDI, set CVBS to line 21. When set to 0, waveform captions are disabled. To enable ancillary digital 708 captions on SDI or SDIALT, select a line number next for the desired output.

Teletext - Waveform and OP47 teletext is supported on CVBS, SDI, and SDIALT. To enable

waveform teletext on CVBS and SD-SDI, set CVBS to line 22. When set to 0 waveform teletext is disabled. To enable ancillary digital OP47 teletext on SDI or SDIALT, select a line number next for the desired output.

VITC - Not supported at this time (2.01.XX)

AFD - AFD is only supported on SDI and SDIALT via SMPTE 2016.

Timecode Configuration - Not supported at this time (2.01.XX)

SMPTE 2038 - The Adtec decoder supports Transport Stream to SDI ancillary data pass-through via SMPTE 2038.

VBI Stats shows the DID/SDID and data count for the SDI outputs if captions or AFD is enabled. The AFD code can be seen in hex and the aspect ratio flag is also displayed.

Web UI - TS Output

ASI Tx configures Service Filtering on the ASI Output. Read more in the [Service Filtering](#) section.

ASI Tx | IP Tx

Apply Cancel

ASI Tx Params ?

ASI Filter: ? ASI TS Source: ?

ASI Output TMR: ? Manual TMR (Mb/s):

Available Services:

Assigned Services:
Inactive
Inactive
Inactive
Inactive

>>
<<

Apply Cancel

ASI Filter - ASI Filter enables or disables the configured RD service filter. Service Filtering

allows users to filter or cherry pick programs destined for the output from an MPTS input. Up to 5 services can be mapped to the ASI Filtered output.

ASI TS Source - ASI TS Source configures the transport stream input to ASI output routing of the IRD.

ASI Output TMR - ASI Output TMR determines the ASI egress rate. When set to AUTO, the default, the output rate will be the sum of all PIDs configured for the output + minimal NULL stuffing. When set to NATIVE, the output TMR is set to match the INPUT source TMR. MANUAL is a user defined rate.

Manual TMR - When ASI Output TMR is set to MANUAL, this field may be configured for a value in Mb/s.

IP Tx configures IP Destinations and Service Filtering for the IP Outputs. A summary table of active configuration can be seen when visiting the IP Tx tab. Click edit next to the desired destination to configure parameters. Read more about protocols in the [IP section](#).

Apply Cancel

IP TS Routing

IP TS Source: ① ASI ▼

IP Destinations ②

IP Dest.	IP Tx Mode	Filtering	Type	Destination	Rate	Modify
1	OFF	NO FILTERING	UDP	226.0.1.59:2000	AUTO	Edit
2	OFF	NO FILTERING	UDP	226.0.1.60:2000	AUTO	Edit
3	OFF	NO FILTERING	UDP	226.0.1.61:2000	AUTO	Edit
4	OFF	NO FILTERING	UDP	226.0.1.62:2000	AUTO	Edit

Apply Cancel

Destination 1 Params

Multicast Mode: ⓘ	OFF ▼	Unicast Gateway: ⓘ	0.0.0.0
IP Tx Mode: ⓘ	UDP/RTP Tx ▼	RTP: ⓘ	OFF - Use UDP ▼
Multicast IPA: ⓘ	226.0.1.59	Multicast Port: ⓘ	2000
Type of Service: ⓘ	NORMAL ▼	Time-to-Live: ⓘ	7
FEC Mode: ⓘ	OFF ▼	FEC Parameters:	L: 14 D: 7
DVB Per IP: ⓘ	7 ▼	Multicast Connector: ⓘ	▼
IP Destination 1 TMR: ⓘ	AUTO ▼	Manual TMR (Mb/s):	AUTO
IP Filter: ⓘ	DISABLED ▼		

Available Services:

>>

<<

Assigned Services:

Inactive

Inactive

Inactive

Inactive

Inactive

Apply
Cancel

IP TS Source - IP TS Source configures the transport stream input to IP output routing of the IRD.

NOTE: This is a GLOBAL IP setting. IE, Each IP destination can have it's own set of filtered programs, but each program set must come from the same TS input source.

Multicast Mode - Multicast can be turned OFF or set to SEND mode. SEND Mode transmits the current encode via the GigE port. Multicast group IP and Port addresses must be specified.

Unicast Gateway - The Unicast Gateway automatically handles IP routing for unicast transmissions. This must be configured if the outgoing unicast requires a different gateway from the configured system default gateway. A route is automatically added when the unit is configured for transmit and a Unicast Gateway exists. The route is deleted if set to 0.0.0.0 or Multicast Mode set to OFF.

NOTE: An unwanted route removal corner case exists at this time. This can occur for applications requiring the same send IP address and the same unicast gateway IP for more than one destination. When one of the mirrored destinations is disabled the shared route will be deleted. If this type of application is required, only use one Unicast Gateway for the group of matching send IP addresses.

IP Tx Mode - IP Tx Mode controls the protocol used for transmitting a transport stream over IP. UDP / RTP or TCP. More information can be read about these in the [IP section](#).

RTP - RTP allows for sequence numbering and timing, which are crucial for the accurate playback of an audio or video data stream.

Note: This field may be edited if Multicast Mode is set to SEND and IP Tx Mode is set to UDP/RTP.

Multicast IPA - The IP Address of which the Multicast or Unicast is broadcast. Multicast addressing supports the transmission of a single IP datagram to multiple receivers. Valid Multicast addressing range is 224.10.XXX.XXX to 239.XXX.XXX.XXX. Unicast addressing sends a single IP datagram to only one receiver. The Unicast address will be the unique IP of the receiving device. Note: Either a Multicast or Unicast address may be entered into this field when Multicast Mode is set to SEND.

Multicast Port - Port number are used for sending UDP transfers in conjunction with Multicast IPA. The valid range is 0-65535. If the port number is set to 0, then no UDP transfers will take place. 2000 is default.

Note: This field may be edited if Multicast Mode is set to SEND.

Type of Service - Type of Service helps define how the network should make negotiate queuing between throughput, delay, reliability, and cost.

Time-to-Live - Time to live is a numeric value from 1 to 255 that specifies the number of iterations or transmissions the packet can undergo before it is discarded. The default value is 7.

FEC Mode - The Forward Error Correction technique implemented in this encoder conforms to the SMPTE 2022-1-2007 standard for the carriage of real-time Video/Audio content over IP networks. When enabled, the encoder will send two FEC streams to the same destination IP address as the source stream, using destination port plus two and destination port plus four. The FEC requires two parameters, L and D, affecting FEC bandwidth and recovery capacity. The standard places three restrictions on these parameters; L is greater than or equal to 4 and less than or equal to 20, D is greater than or equal to 4 and less than or equal to 20, and the product of L and D is less than or equal to 100.

NOTE: RTP must be ON before FEC streams start. FEC streams IP TTL matches the source stream.

DVB Per IP - DVB per IP configures the amount of DVB 188 Byte Transport Stream packets for an IP packet payload. 1 DVB packet per IP packet has the lowest impact on service interruption if 1 IP packet is lost, however it has the highest data overhead due to packing inefficiency. 7 DVB packets per IP packet has the highest impact on service interruption if 1 IP packet is lost, however has the lowest data overhead due to packing efficiency. 4 DVB packets per IP packet is a compromise between efficiency and service impact. 7 DVB packets per IP packet is the default value and recommended for most applications.

Multicast Connector - The multicast connector configuration determines whether the IP stream will be sent out the IP1 (0) or IP2 (1) port.

IP Destination # TMR - IP Destination TMR determines the IP transport egress rate for the specified destination. MANUAL is a user defined rate.

NOTE: This value is only selectable if the SVC-FLTR-KEY is enabled.

Manual TMR - User defined IP TMR in Mb/s.

IP Filter - IP Filter enables or disables the configured RD-70 service filter. Service Filtering allows users to filter or cherry pick programs destined for the output from an MPTS input. Up to 5 services can be mapped to the IP Filtered output.

NOTE: This value is only selectable if the SVC-FLTR-KEY is enabled.

Web UI - System

System allows setup of Network, SNMP and Date/Time configurations. The system may also be rebooted from this tab.

Input	Video	Audio	CAS	VBI	TS Output	System	Security	Upgrade	Help
-------	-------	-------	-----	-----	-----------	--------	----------	---------	------

Apply
Cancel

Uptime: ⓘ 0 Days, 19 Hours, 23 Minutes, 50 Seconds

Device Name: ⓘ Reboot Device

Gateway Address: ⓘ <input type="text" value="192.168.11.1"/>	Nameserver IP: ⓘ <input type="text" value="0.0.0.0"/>
IP 1 Port (Default Management)	IP 2 Port (Default TSoIP Tx)
<input type="checkbox"/> DHCP : ⓘ	<input type="checkbox"/> DHCP : ⓘ
IP 1 Address: ⓘ <input type="text" value="192.168.11.74"/>	IP 2 Address: ⓘ <input type="text" value="192.168.0.74"/>
Subnet Mask: ⓘ <input type="text" value="255.255.255.0"/>	Subnet Mask: ⓘ <input type="text" value="255.255.255.0"/>
	IP 2 Management: ⓘ <input type="text" value="ON"/>

MAC Address: 0:90:1f:2:1:98	MAC Address: 0:90:1f:2:1:99
Link Status: Up	Link Status: Down
Link Speed: 100 Mb/s	Link Speed: 1 Gb/s

NTP Address: ⓘ <input type="text" value="0.0.0.0"/>	Time Zone: ⓘ <input type="text" value="CST-6CDT,M3.2.0/2,M11.1.0/2"/>
Date: ⓘ <input type="text" value="09/15/2015"/>	Time: ⓘ <input type="text" value="11:36:52"/>

SNMP: ⓘ <input type="text" value="OFF"/>	
Read Only Password: ⓘ <input type="password" value="****"/>	Read-Write Password: ⓘ <input type="password" value="****"/>
Trap Community: ⓘ <input type="text" value="public"/>	Trap Sink: ⓘ <input type="text" value="127.0.0.1"/>

Apply
Cancel

Device Name - Device name is the host name for the unit. When a unit is manufactured, it is given a name that combines the product type and the serial number of the unit. Ex. ProductName-012345. This name is broadcast to local subnets. By using the built-in Bonjour® locator in the Apple® Safari® browser or the plug-ins readily available for Internet Explorer® or Firefox® browsers, you can locate Adtec Digital devices via serial number or custom name.

Gateway Address - Gateway IP is an address on a TCP/IP Network that serves as an access point to another network. Each Adtec Digital device is limited to one Gateway IP.

Nameserver IP - *NAMESERVER* is used to manage connectivity to network attached

storage. Setting *NAMESERVER* may conflict with *DHCP* which acquires *NAMESERVER* automatically. Do not set *NAMESERVER* when *DHCP* for *IP1* is active.

DHCP - Enables your device to extract an IP Address from a DHCP server for use as the Ethernet IPA for the IP 1 port. The overall purpose of this is to reduce the work necessary for administration of a large IP network. Consult your Network Administrator before using DHCP. This setting requires the presence of a DHCP server on the LAN. The DHCP server needs to be able to notify a DNS server of the IP address associated with the unit name (which is the Device Name).

IP Address - The Internet Protocol (IP) Address used for the IP # port of the device. The device's IP address must adhere to certain standards and not conflict with the IP address of any another device on the network. IP address(es) with 0 or 255 in them are invalid. Please consult your organization's Network Administrator before assigning an IP address to a unit. An IP address of 0.0.0.0 can be assigned and will effectively disable the unit's network capabilities.

Subnet Mask - The Subnet Mask sets the network subnet mask assigned to the unit. Consult your organization's Network Administrator for the IP Subnet mask for your unit(s).

MAC Address - Displays the units physical MAC address.

Link Status - Displays whether the connector detect link or not.

Link Speed - Displays the connected link speed if the link is up.

NTP Address - NTP Address is the IP address of an external source for time. It should be entered in decimal form XXX.XXX.XXX.XXX . Setting the NTP Address to 0.0.0.0 turns NTP off.

Time Zone - Time Zone is used to specify the name of your timezone, the offset is in hours from UTC and a Daylight Savings Setting.

Date - This field will auto-populate if your device is networked to an NTP server; it can also be used to manually designate a time-of-day for timekeeping and internal scheduling.

Time - This field will auto-populate if your device is networked to an NTP server; it can also be used to manually designate a time-of-day for timekeeping and internal scheduling.

SNMP - Controls the status (ON/OFF) of the Simple Network Management Protocol (SNMP) feature. We support SNMPv2c version.

Read Only Community - The Simple Network Management Protocol (SNMP) Read-Only Password. Default Value: "adtec"

Read Write Community - The Simple Network Management Protocol (SNMP) Read-Write Password. Default Value: "none"

Trap Community - The Simple Network Management Protocol (SNMP) trap community.
Default Value: "public"

Trap Sink Address - The Simple Network Management Protocol (SNMP) trap sink. Default Value: "127.0.0.1"

Web UI - Security

See the [Web UI Authentication](#) article for information on Security.

Web UI - Upgrade

Upgrade Firmware

See the [Web UI Upgrade](#) article for information on unit and demodulator firmware upgrades.

Upgrade Features

See the [Web UI Features](#) article for information on unit and demodulator feature keys.

Web UI - Help

Help provides an HTML version of this manual, firmware release notes, API notes, SNMP MIBs and licenses used in making the product.

API Interface

The API or Application Programming Interface is an advanced interface to interact with Adtec products. This interface is available for special cases such as system integration, network management systems (NMS), advanced troubleshooting, developers and testers. An operator does not generally interface with the API directly, but instead will interface with third party software. If an operator does need to interface with the API, generally it will be for troubleshooting purposes with the aid of a support representative. API commands and documentation can be found on the Help tab of the product and the Adtec Digital website.

The API is available both via network (Telnet) and serial (COM2) connectivity.

Telnet (standard 23 port)

To connect to an Adtec unit using a terminal session, the IP address of the unit must be known. See earlier instructions on setting IP address via the front panel.

Windows XP, MAC and Linux Instructions:

Using a terminal window, complete the following:

Step	Action
1	Type 'telnet x.x.x.x' in a terminal window, without quotes, where x.x.x.x is the IP address of the unit.

2	Press <Enter>.
3	When prompted for a username, enter adtec.
4	When prompted for a password, enter none.

Once the prompt "User 'adtec' connected" is seen, the session is open and API commands are ready to be entered.

Microsoft Windows 7 and higher may have telnet disabled by default. An operator may enable telnet or they may download a third party program. PuTTY is a popular API program that offers both network and serial control options. To enable the default telnet client installed on Windows 7 or higher:

Step	Action
1	Click on Start -> Control Panel
2	Click on the Programs category
3	Click 'Turn Windows features on or off' under the 'Programs and Features' category
4	Place a check mark inside of 'Telnet Client' and click OK
5	Please be patient as Windows enables Telnet capability, it can take several minutes.

SNMP Interface

The SNMP or Simple Network Management Protocol interface is an advanced interface to interact with Adtec products. This interface is available for special cases such as system integration, network management systems (NMS) and developers. Third party software is usually written around this interface so users may interact with the product. An operator does not generally interface with SNMP directly, but instead will interface with third party software.

SNMP MIB's (Management Information Base) that describe the interface can be found on each product's Web interface under the Help tab.

RD Web UI Authentication and Security Features

Summary

Adtec products provide flexible web authentication and security features so they may thrive in unique and dynamic broadcast environments. Adtec has recently added 'ADVANCED' UI authentication to allow administrators without external control systems provide unique read/write Web UI capabilities for each individual web operator. Web UI authentication can also be turned completely OFF in environments where password security is not required.

Adtec products also offer capability to change the listening web port to prevent external port 80 attacks, turn off management from the IP2 port and add a 'STEALTHIP' or safe list of allowed IP addresses to access web/ftp/telnet services.

This document will describe Web UI authentication behaviors and the available security features.

Web UI Authentication Modes

The Web UI authentication can be configured to operate in one of three modes.

- OFF - No authentication is required. When set to OFF, all users that navigate to the web interface will be granted admin privileges and will be directed to the 'home' page when typing in the IP address of the unit. The 'home' page is the 'Input -> RD Services' page on RD products and the 'Services -> ASI Transport' for EN products.
- ON - Default behavior. All users that navigate to the web interface will be directed to a 'Splash' page that consists of a 'Proceed to Login' button, support links and information about the unit including serial Number and firmware version. The admin username is fixed at 'adtec' and can *not* be changed. The default password is 'none', but may be changed via the 'Security -> Password' configuration. This password changes all services including Web UI, FTP and Telnet.

RD-71



Quick Links

[Documentation & Technical Support](#)
www.adtecdigital.com
Serial: 201515224
Firmware: 2.00.18

Proceed to Login

Log on Splash Screen when set to 'ON'

- **ADVANCED** - All users that navigate to the unit will be prompted with a username and password Login box. As of date 8/28/2015, the default username is 'adtec' and the default password is 'none' for the administrator. This password is stored differently than when in the 'ON' mode and defaults to 'none', regardless of previously changed passwords when set to the 'ON' configuration. The 'Login as Guest' button may be used to view the Web UI in 'read only' mode.

Adtec Digital: Login

User:

Password:

Web UI Authentication Advanced mode

Users with write access get administrative controls and are allowed to change any configuration available in their 'view' mode. It is recommended to keep one admin user (adtec or other) that is able to access all tabs.

Create a user:

Step	Description
1	Click the 'Add User' button to add a custom user.
2	Fill in the desired username
3	Fill in the desired password for the new user
4	Verify the user can login by setting the 'Active' configuration to 'YES'
5	Choose read only or write Access by configuring the 'Write Access' configuration to 'YES' (write) or 'NO' (read only).
6	De-select tabs that are not desired to be viewed by the new user. IE. If the 'Security' tab is grayed out, the newly created user will not be able to navigate to the Security tab. Sub-tabs can also be chosen.
7	Click Apply and share credentials with the desired user/operator.

Change UI Authentication:

UI Authentication: ? ADVANCED + Add User

Username	Write Access	Active	Actions
guest	No	Yes	Edit
adtec	Yes	Yes	Edit

Username: Active: YES

Password: Confirm Password:

Write Access: YES

Pages: Highlighted tabs will be visible to this user. Grey tabs will be hidden.

Input	Video	Audio	CAS	VBI	TS Output	System	Security	Upgrade	Help
RD Services	RF Params	IP Params	Bars Tones & ID						

user1 without navigation capability to System, Security or sub-tabs of 'TS Output'

User administration is possible for all users with Write Access to the Security page. The 'adtec' and 'guest' users are default users and can't be deleted, but they may have their permissions modified.

When the 'user1' operator logs in, they will only see tabs configured for them.

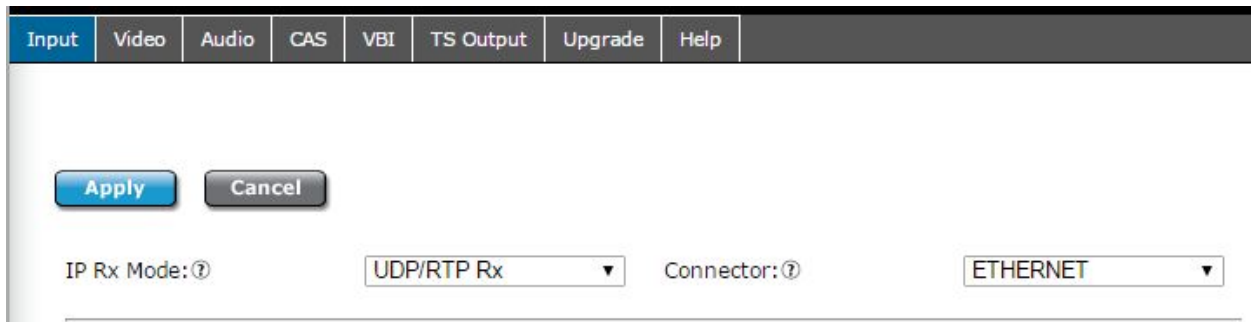

example: user1 is does not view 'System', 'Security', 'RD Services', 'RF Params' and 'Bars Tones & ID' tabs after login as configured

If a user has 'Write Access' configured to 'NO', user will receive permissions error when attempting to change any values.



Other security features

HTTP Port

The Web UI listening port or 'HTTP Port' may also be changed to prevent unwanted users from finding the Adtec web interface at the default port. If the port is changed, the web address for login will need updated.

For example if the unit IP address is 192.168.10.48, standard web navigation can occur by typing `http://192.168.10.48` in the browser address bar. If the port is changed (to 8000 for example), then user would need to type `http://192.168.10.48:8000` to navigate to the unit. All requests on default HTTP port 80 would be denied.

Stealth IP address

The Stealth IP address feature allows up to 4 IP addresses as a 'safe list'. Any IP addresses listed in the 'safe list' are allowed to enter the box. Any IP addresses that aren't listed will be denied all access. When enabling this feature, it is recommended to enter the IP address of the

PC configuring the unit with first. Otherwise, you will be locked out. The Stealth IP address feature only supports IPv4 addresses at this time.

IP2 / GigE Management

By default, the IP1 (eth0) ports of Adtec products are reserved for management and the IP2 (eth1) ports are reserved for Transport Stream I/O. The ports can be used for either management and/or transport with the 'Multicast Connector' configurations on TSolP Rx and Tx pages. To prevent unwanted users from managing the device through the IP2 port, an IP2 Management configuration has been made available on the System tab. This defaults to ON (allow management from both IP1 and IP2 ports), but may be turned to OFF (only allow management from IP1 interface) to further secure the device. Turning this feature OFF disables Web UI, FTP and Telnet connectivity on the IP2 port.

Operational Information

DVB-S / DVB-S2 AUTO Modes

The RD-71 with L-Band demodulator (LB) option supports automatic detection of modulation type and symbol rate on two RF inputs. In fully automatic mode, the minimum configuration requirement is L-Band frequency. The demodulator is running in fully automatic mode when the type is set to 'AUTO' and the symbol rate is set to '0' or 'AUTO'.

Notes about demodulator:

- Please note that some carriers may not fully acquire if they fall outside of the allocated resources available by the hardware. Please reference the demodulation resource [table](#) located in the appendix for supported modes.

DVB-S2 - Recommended use of Pilots

The use of DVB-S2 pilots within the modulated carrier are recommended under certain conditions. With the following configurations, Pilots are recommended:

- High order modulation schemes: 16APSK and 32APSK
- Low code rates QPSK: 1/4, 1/3, 2/5, 1/2, and 3/5
- Low code rates 8PSK: 3/5, 2/3, 3/4, and 5/6
- Low symbol rates: <5 Mbaud for free running DRO LNB
- Low symbol rates: <3 Mbaud for Phase Locked DRO LNB

Single Stream (no restart)-PRX only model

Multistream Mode:

If there is any encoder/modulator rate mismatch there can be TS errors, Single Stream (no restart) should be selected

RF Profiles

The RD has capability to create profiles from the current running RF configuration and load it at a later time.

To create a profile:

- Enter the desired RF parameters required for the profile
- Click the Apply button to save information to the currently running configuration
- Click the 'Create RF Profile' button next to the respective tuner that is desired to be stored.
- Name the RF Profile and click OK. Please note that only Alphanumeric and underscores are allowed in the profile name. If Spaces " ", Dashes "-", or other special characters are entered, an error window will pop up.
- All drop downs will populate with the created RF profile name

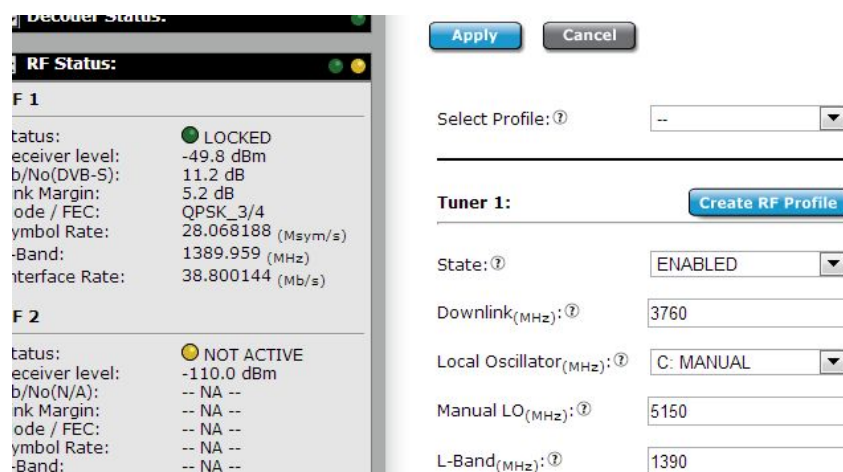

To load a profile:

- Select an RF profile from the 'Select Profile' list above the desired tuner.
- After selection, the profile will be "previewed" and all configuration fields will display the contents of the profile.
- If the profile is desired to be loaded into the respective tuner, click the Apply button. If the profile is not desired, the Cancel button may be clicked or the double dash profile "--" may be selected to exit from preview mode. Exiting preview mode will return to display the current running configuration.

Profile Management:

- The Manage RF Profiles box gives users the ability to Delete (Red X button) or Download (Downward Yellow button) RF Profiles from the IRD.
- Select a Profile and click the Delete button to have the profile removed from the device and all drop down boxes.
- Select a Profile and click the Download button to have the profile downloaded to your PC.
- The standard Upload button next to the Logs and Thumbnail button may be used to

Upload a profile to other devices.

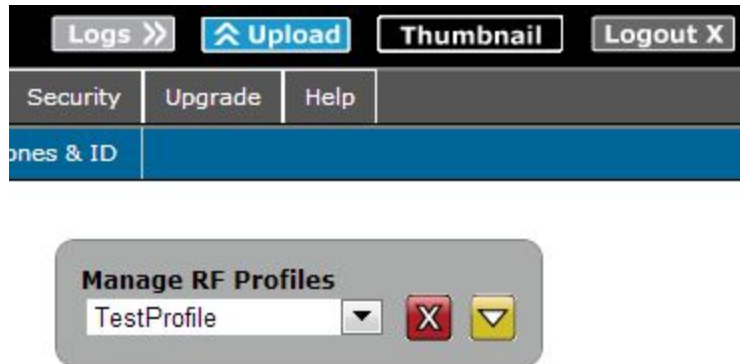

UDP / RTP / FEC / TCP IP Rx

The RD-71 supports a number of IP based protocols for the reception of transport streams via private and public networks. The RD-71 will automatically determine if an IP stream is UDP, RTP, or a SMPTE-2022 FEC stream. TCP reception is a less common implementation for transmission of broadcast transport streams, but has recently been added to the RD-71.

UDP (User Datagram Protocol) multicast/unicast streams are commonly used for broadcast transport streams in local or private networks that contain little to no packet loss. UDP offers no protection against dropped packets or packets received out of order (usually due to packets taking a different amount of time to traverse network devices). Due to the low reliability of UDP, it is NOT recommended to be used over the public internet or in environments where the potential of packet loss, increased jitter, or out of order packets is high. If packets are lost or received out of order, service anomalies will occur. The RD-71 supports up to 100Mb/s when a 7 DVB Packet payload exists for each UDP packet.

RTP (Real-time Transport Protocol) is another type of multicast/unicast stream that is better to use than UDP in some environments. RTP is built upon the building blocks of UDP, but adds packet sequence identification. Packet sequencing gives a receiver the information needed to detect and correct packets that were received 'out of order'. RTP is highly recommended when timely delivery of each consecutive packet may not be guaranteed. The RD-71 supports up to 100Mb/s when a 7 DVB Packet payload exists for each RTP packet.

RTP + FEC or SMPTE-2022 is an additional method used in dealing with lost packets, where RTP alone can only tolerate packets received out of order. FEC (Forward Error Correction) streams add overhead to the overall data rate, but add protection in case of a lost packet. FEC (detection and correction of lost packets) adds latency and data overhead as opposed to UDP where no protection mechanisms exist. The amount of packet redundancy and overhead can be configured at the RTP/FEC transmitter. Each multicast/unicast FEC stream is transmitted on base port N and two FEC streams are sent on N+2 and N+4 respectively. When receiving FEC streams behind firewalls, please bear in mind that two additional ports (

N+2 and N+4) must be allowed through for proper error recovery to occur. The RD-71 supports up to 45Mb/s SMPTE-2022 when a 7 DVB Packet payload exists for each RTP packet.

TCP (Transmission Control Protocol) support, a connection based protocol, has recently been added at an attempt to overcome some of the fundamental limitations of UDP and RTP. UDP and RTP are 'one way street' types of protocols where the transmitter sends data and never knows if the data makes it to the destination. TCP streams generally have higher latency (takes longer to transmit data and verify data has been transmitted), but are more reliable because each packet is accounted for by the receiver. If a packet is lost, the transmitter will be informed to re-transmit the packet. The transmitter and receiver continue to communicate about the quality of the reception and attempt to adjust packet delivery accordingly. The TCP mechanism when combined with large IP receive buffers can be more forgiving with packet loss, jitter, and out of order packets. The RD-71 supports up to 15Mb/s when a 7 DVB Packet payload exists for each TCP packet. Multicast is *not* supported with TCP streams.

The RD-71 supports both unicast (point to point) and multicast (broadcast) streams. The RD-71 operates in UDP/RTP mode by default. To setup an IP Rx session, first configure the IP Rx operation mode. A unit reboot is required (WebUI asks for confirmation when changing) when changing between UDP/RTP Rx and TCP Rx modes.

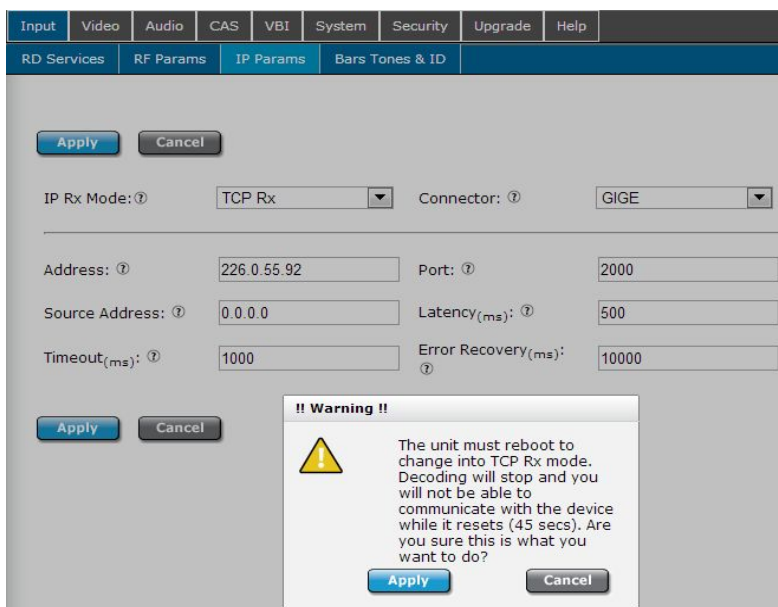

Multicast Reception - Address

To receive a multicast (UDP/RTP/SMPTE2022) stream, place the multicast address wished to view in the 'Address' field. This address must match the same address used on the multicast transmitter. Multicast IP address ranges are 224.xxx.xxx.xxx to 239.xxx.xxx.xxx, where $0 \leq xxx \leq 255$. If you are new to multicast and attempting a first time connection, 226.0.1.1 is a common address to start with. Please verify transmitter address

configuration.

Optionally, the source specific multicast address (The actual IP address of the sending device) may be entered for IGMPv3 applications. Configuring the Source Address will allow multicasts to be received from the entered address and entered address only. This configuration is non-functional for Unicasts. For IGMPv2 applications, the source address recommendation is 0.0.0.0.

Unicast Reception - Address

To receive a unicast (TCP/UDP/RTP/SMPTE2022) stream, enter 0.0.0.0 in the 'Address' field. The unit will be 'listening' for any streams sent directly to it. Refer to your IP transmitter documentation for proper configuration of the transmitter.

Unicast/Multicast Reception

Enter the port number in the 'port' field. The port number must match the port number used on the transmitter where the range is 0 to 65535. When 0, multicast is disabled. If you are new to multicast and attempting a first time connection, 2000 is a common port to start with. Please verify transmitter port configuration.

Choose the IP Rx 'Connector' dependent upon network setup.

Once IP Rx is configured, click Apply.

Visit the Input -> Service tab and click the 'Select first found' radio button to enable IP reception. IP service names will populate in the service list.

RD-70
Version 0.02.00
Temperature: 34(C)

Decoder Status:
Status: ● DECODING IP
Transmux Rate: 31000037 (b/s)
Service ID-Name: 1-EN-81 ...
Service Provider: Adtec Digital
Bars/Tones/ID: OFF/OFF/OFF
Decrypt Status: ■ Decrypting

RF Status:
Active Input: RF 1
Status: ● LOCKED
Receiver Level: -54.49 dBm
Es/No(DVB-S2): 22.68 dB
Link Margin: 9.17 dB
Mode / FEC: 32APSK_3/4
Pilot: ON
Interface Rate: 124.120864 (Mb/s)

IP Status:
Status: ● PLAYING
IP Addr./Port: 226.0.55.92/2000
Average Bitrate: 31000037 (b/s)
Buffer %/Level: 18% / 506 (ms)
Protocol: RTP
FEC Detected: YES
FEC L/D: 20 / 4
DVB per IP: 7

Services Menu:

ASI Select first found

Select	Service ID	Service Name	Service Provider	Details
<input type="button" value="Select"/>	1	EN-81	Adtec Digital	<input type="button" value="Details"/>

RF1 Select first found

Select	Service ID	Service Name	Service Provider	Details
<input type="button" value="Select"/>	1	EN-81	Adtec Digital	<input type="button" value="Details"/>
<input type="button" value="Select"/>	2	EN-91	Adtec Digital	<input type="button" value="Details"/>
<input type="button" value="Select"/>	3	EN-81	Adtec Digital	<input type="button" value="Details"/>
<input type="button" value="Select"/>	4	EN-91	Adtec Digital	<input type="button" value="Details"/>

RF2 Select first found

-- No Services Found --

IP Select first found

Select	Service ID	Service Name	Service Provider	Details
<input type="button" value="Select"/>	1	EN-81	Adtec Digital	<input type="button" value="Details"/>

'Select first found' is also available via the Front Panel -> Services Menu -> Select First configuration. Use the left/right arrows to select [IP], press select, then press enter to start IP receiving.

Dolby E, Dolby D, LPCM, and Mpeg 1 Layer 2

As of 0.01.00 firmware, the RD-71 supports 16 channels of SDI embedded audio output with support of up to four audio pass-throughs, up to 8 pairs (sixteen channels) of aligned Mpeg 1 Layer 2 audio, and up to 8 pairs of Dolby Digital decoding. An audio pass-through consists of a Dolby E 20 Bit, Dolby E 16 Bit, Dolby Digital, or a Linear PCM stream that is preserved (not decoded) from the transport stream and embedded on the SDI output.

Mpeg 1 Layer 2 decode support includes 48kHz 32 - 384kbps. Interoperability support includes stream type 0x03 (sometimes called Mpeg 1 Layer 2), stream type 0x04 (sometimes called Mpeg 2 Layer 2), PES aligned/unaligned audio, Mono (with audio duplication feature), Dual Mono, and Stereo decoding.

Dolby Digital decode support includes a stereo output pair for each Dolby Digital Audio PID assignment (multi-channel Dolby Digital 5.1 for example is down-mixed to 2/0).

Note: Encoder must support alignment for aligned audio feature.

The RD-71 automatically configures the audio engines upon acquisition of a program when engines and sdi matrix are configured to 'AUTO'. The audio is automatically output based on ascending audio PID order from the selected program, not PMT order, to retain encoder compatibilities. The left hand status panel of the Web UI shows current active SDI audio output. Advanced configuration is available via the Audio tab for users that need to select custom PID's, disable audios, and duplicate audio pairs.

Dolby E line placement is handled automatically to meet Dolby Labs specification. Some users may need custom line placement. If the customer Dolby E line placement selection is out of specification, the RD will revert line placement to the automatic in range value. Please see [table](#) in notes for Dolby E line placement recommendations.

Notes:

- Encoder must support alignment for aligned audio feature.
- Pass-through audio bit-rates are now displayed on the left hand status panel. Please note that these are live calculated bit-rates and will not show a static number.

Dolby Labs - Dolby E recommended line position table

	625 25	1080i 50	1080 p 50	720p 50	525 29.97	1080i 59.94	1080p 59.94	720p 59.94
Earliest	8	13	26	17	12	18	35	23
Ideal -80us	11	19	37	25	13	21	42	28
Ideal +- 80us	12	21	42	28	14	24	47	32
Ideal +80us	13	23	103	31	16	26	52	35
Latest	30	53	105	70	26	48	95	63
Adtec Auto	19	30	42	35	19	30	47	40

AFD - Active Format Description

Active Format Description (AFD) contains aspect ratio and handling information utilized to aid in picture presentation of downstream devices. This is used most often by down-converters and set top boxes.

AFD carriage can be carried within a transport stream as a unique ANC PID (ancillary pid), within the video elementary stream as SEI data (H264), or user data (MPEG2). The RD-71 does not support AFD via an ANC PID at this time.

The RD-71 AFD implementation preserves the native AFD code from the video elementary stream and is inserted into the SDI ancillary data output on DID/SDID 0x4105. The SDI output is not modified in anyway based upon this data. SDI line number for AFD carriage is configurable via the VBI tab. The DID/SDID, AFD code, and aspect ratio flag can be seen in the VBI Output table via the VBI tab.

Genlock System

The RD-71 can synchronize its SDI and CVBS outputs to an external sync signal using the SYNC IN input and the Genlock control system. The SYNC IN input signal's frame synchronization is used to generate SDI and CVBS output pixel clocks, frame synchronization and audio clocks that are locked to the SYNC IN reference. The video decoder will automatically skip or repeat video frames as needed to adjust to differences between the SYNC IN clock and the decoder source clock (which is synchronized to the stream's PCR data). The audio system uses a sample rate converter to adjust to differences between the decoder source clock and the SYNC IN clock.

The Genlock system will automatically cross lock for all resolutions within the 59.94 Hz standard or all resolutions within the 50 Hz standards. It does not cross lock between 50 Hz and 59.94 Hz standards at this time. This allows the SYNC IN signal to be valid for compatible decoded streams (example: An NTSC black burst SYNC IN signal can be used to Genlock a 1080I59 feed).

The Genlock system can be configured in two modes. Genlock *SLAVE* mode is used when the SYNC IN signal is synchronous with the decoded stream, ie, both signals are using the same 27 MHz source clock. This mode allows two RD-71's to be used for receiving 3D/4K signals or when the decoded source is using the same clock base as the SYNC IN. This mode bypasses the need for the audio sample rate converters. Genlock *REMOTE* mode is used when the SYNC IN signal does not use the same 27 MHz clock source as the decoded stream. This mode enables the audio sample rate converters for audio output.

The SYNC IN input will accept standard analog video sync for NTSC, PAL, 480I/P, 576I/P, 720P, and 1080I/P from Composite Video (CVBS). The input can accept Bi-level and Tri-level sync signals. The signal is processed to create synchronous audio and video clocks and to frame align the SDI and CVBS outputs with the input sync signal. Generally, the output will be automatically aligned within a few pixel clocks of the input.

If the Genlock system is locked, and the SYNC IN is removed, the system will attempt to maintain the clocks and frame reference with the last known locked frequency. There may be some clock drift over time. If the decoder is stopped and restarted in this mode, the Genlock system will use the decode source clock and operate in a 'free-run' mode until the reference is re-applied. The video and audio will be lost for a short time when the SYNC IN reference is restored.

When the Genlock mode is changed, the Genlock system will automatically be reset. This will cause a brief disturbance of the video and audio outputs.

TS Out Decrypt

TSO or Transport Stream Out Decrypt determines how BISS encrypted transport streams are processed. This configuration provides end users flexibility on how the RD is used. The TS Out Decrypt configuration determines if the ASI output should mirror the selected input (OFF), thus preserving any encrypted streams or if it should be decrypted / free to air (ON).

TS Out Decrypt should be set to OFF, the default configuration, if the IRD is to be used in a confidence decode / turn around application. A confidence decode / turn around application can involve the IRD being used a turn around device (IP to ASI or RF to ASI) where the user wants to preserve encryption on the ASI output, but also wants to decode one of the incoming programs. This configuration also allows the RD to ingest encrypted MPTS streams that may be over the TSO limit. A sample diagram of how the transport stream is passed to the ASI output through the system is shown below.

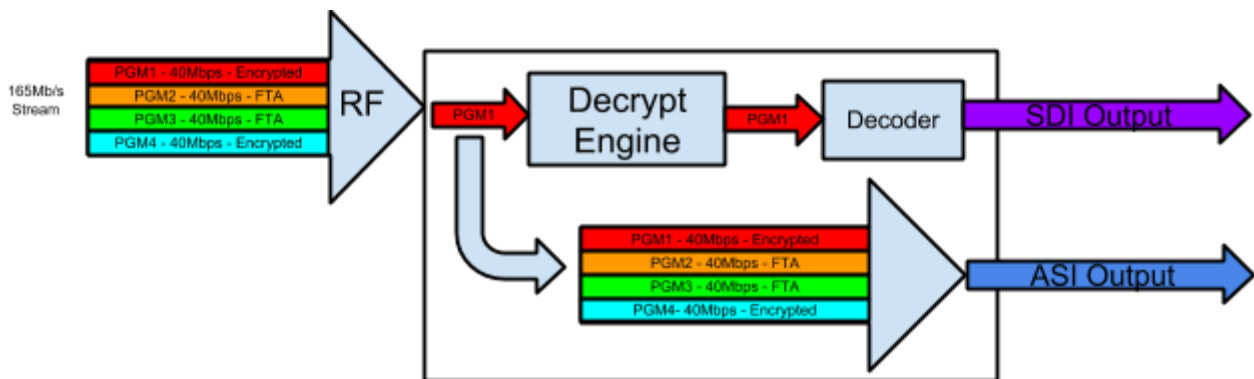

If the user wants to use the IRD as a decoder and decrypter, the TS Out Decrypt configuration should be set to ON. All programs will be decrypted with the user supplied BISS key and transported to the ASI output. This application is useful for users that want to redistribute the stream to other non-BISS devices, such as transport stream analyzers or third party decoders. Please note that when in this mode, total transport stream throughput must not exceed the rate stated in the Technical Specifications found in Appendix B.

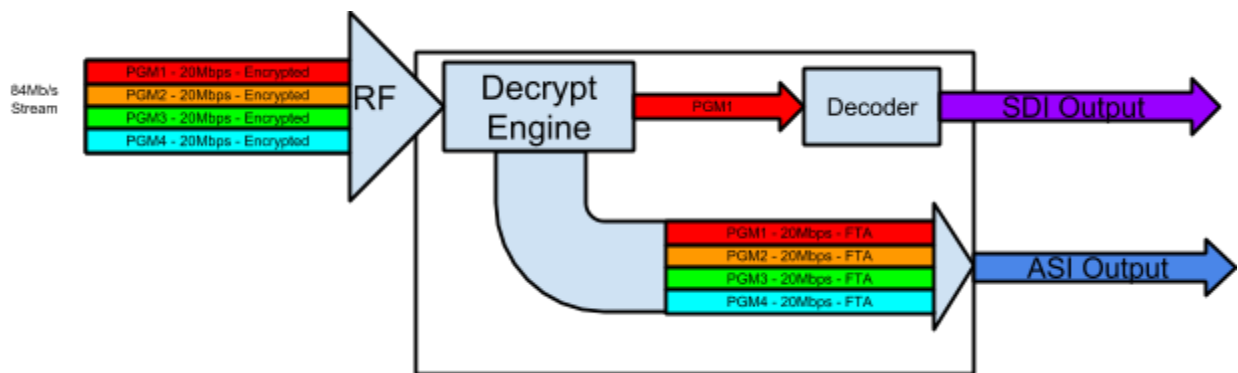

Service Filtering

Terminology:

TS - Transport Stream - A stream of transport packets that contain audio, video and data belonging to one (SPTS, single program transport stream, also known as SCPC.) or several programs (MPTS, multiple program transport stream, also known as MCPC.).

PAT - Program Association Table. This MPEG-2 table lists all the programs contained in the transport stream and shows the PID value for the PMT associated with each program. The PAT is always found on PID 0x0000.

PMT - Program Map Table. This MPEG-2 table specifies PID values for components of programs.

PID - Packet Identifier. This unique integer value identifies elements in the transport stream such as tables, data, or the audio for a specific program.

Program / Service / Channel - A combination of one or more elements (video, audio or data) defined by a PMT.

Summary:

Service Filtering allows an MPTS from the input to be turned into an SPTS or program reduced MPTS on a given output. This is helpful in service turn around applications where all programs are not desired for re-transmission. An example of 5 MPTS to a smaller MPTS output is shown below.

The Adtec RD-71 also has the ability to route Inputs to Outputs, such as route RF2 Input to ASI Output while decoding from RF1. The Service Filter control must be ENABLED for routing to function. The RD-71 does *not* support multiplexing of the inputs. A block diagram of the input routing and filtering is shown below.

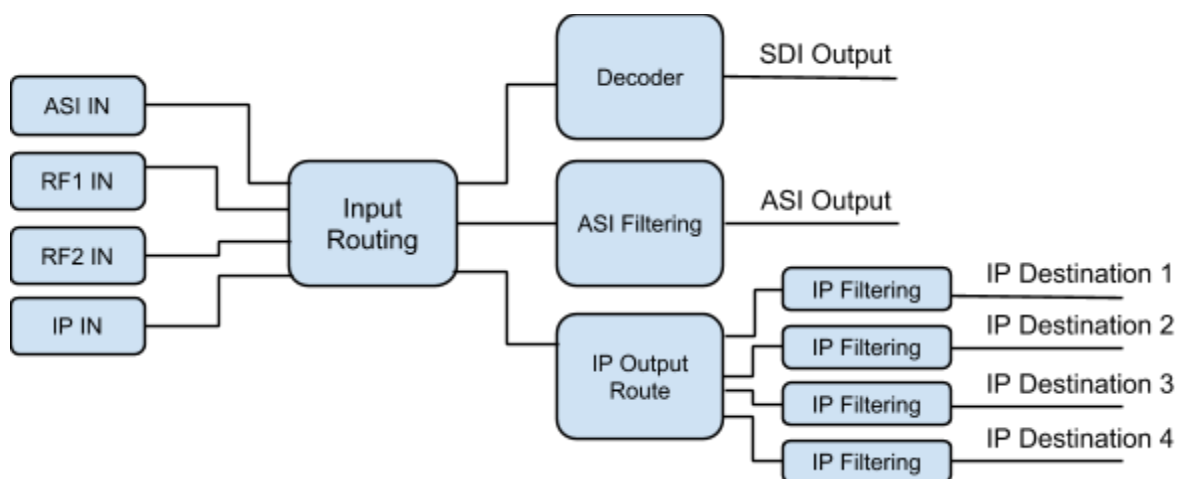

Input to Output Routing and Filtering

The SVC-FILTR key must be enabled to configure Service Filtering. When filtering is enabled, a maximum of 5 programs are allowed on any given output. If filtering is disabled, all programs available on the selected input for decode are available on the output, ie. unit is in service pass through mode and no longer routing.

Configure Service Filter on ASI

To configure service filtering on the ASI output, visit the TS Output -> ASI Tx tab. First choose the ASI Output Source. The ASI Output can be sourced from ASI IN, RF1 IN or RF2 IN, depending on demodulator hardware option.

Then, choose the ASI Output behavior or ASI Output TMR. ASI Output TMR determines the ASI egress rate. When set to AUTO, the default, the output rate will be the sum of all filter PIDs configured for the output + minimal NULL stuffing. When set to NATIVE, the output TMR is set to match the INPUT source TMR. MANUAL is a user defined rate.

Then, choose the service required to filter from the Available Service list. Clicking the right arrow will add the service to the Assigned Service list.

When the ASI Filter is set to ENABLED and Apply is clicked, you shall now see the selected service on the ASI Output.

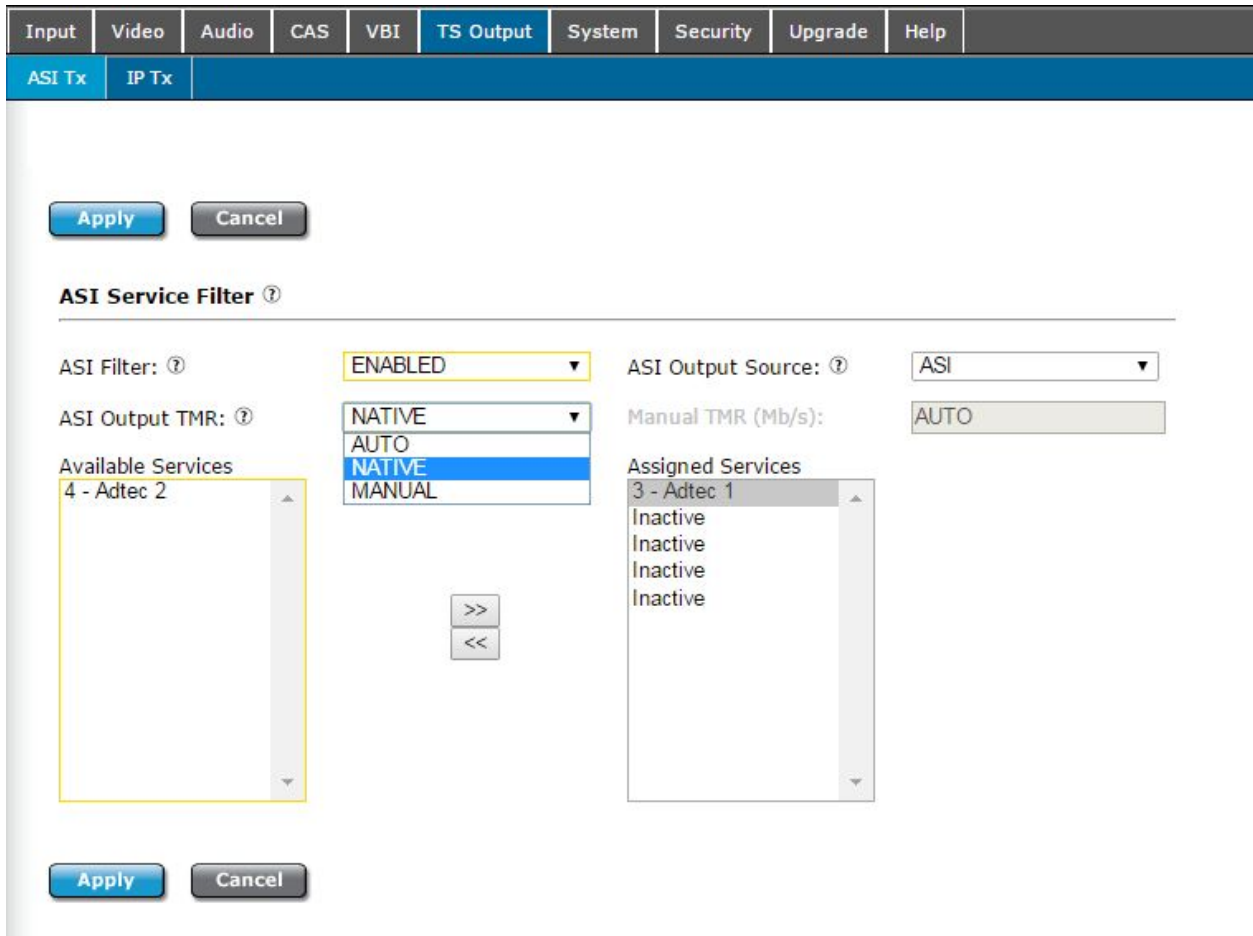

Firmware Upgrade via Web User Interface

Periodically, we will provide firmware updates to our products via our website. (<http://www.adtecdigital.com>) To upgrade your device, download the firmware file from our website and store it locally. Login to the web-based application and navigate to the Upgrade > Firmware tab. Click on the upload button located at the top right of the application. Select the firmware file from your local machine and wait for it to upload. Once it has finished uploading, it will appear in the Available Versions list.

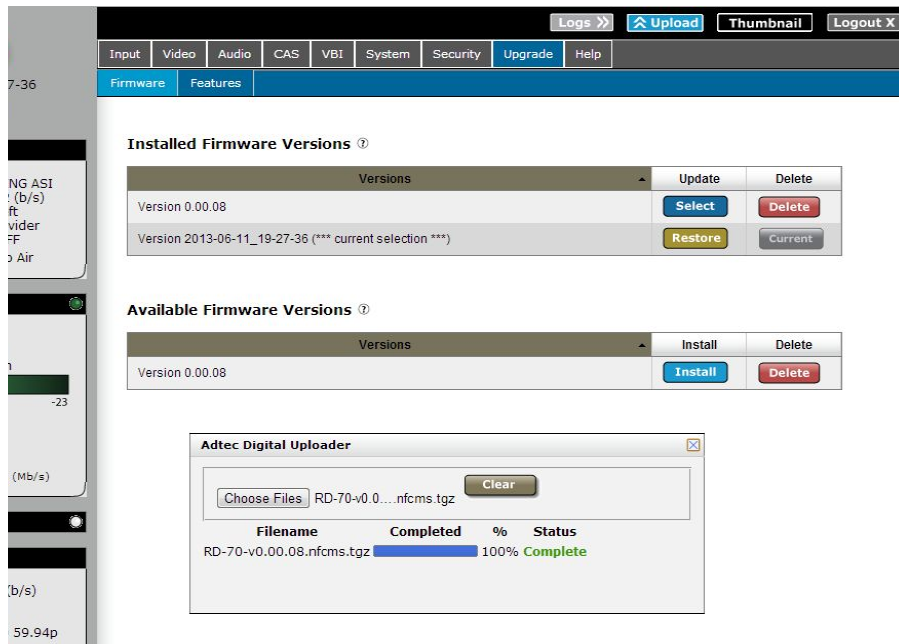

Click on the Install button associated with the new file. Wait for it to completely extract and become available in the Installed Versions List. Once available there, simply click on the Select button associated with the new firmware and wait for your device to reboot.

Demodulator Firmware Upgrade via Web User Interface

In some cases, Adtec may provide a modulator or demodulator firmware upgrade. These are handled separately than standard product firmware upgrades because they can take longer than a product firmware update and should be planned during maintenance windows. Adtec currently has several demodulator versions that include ADV, LB and PRM models. Each demodulator hardware type has a unique demod firmware version and must be upgraded with a compatible version.

To upgrade, first determine the installed demodulator type and firmware version. Visit the Upgrade -> Features tab. The 'BOARDS INFO' table slot 99 will contain the installed demodulator version.

BOARDS INFO

Slot	ID	Name
2	BI20	PCA111 ver 2.0
99	2910	LB ver 102

The above example shows a PRM demod running demod version 1.17. In this case, a 7044AB firmware file name is required to update this demodulator. If a demodulator firmware is provided for any reason, please make sure the firmware type provided matches

the hardware type of the unit it is being installed on. The demod firmware may be upgraded similarly to a product firmware upgrade.

Click on the upload button located at the top right of the application. Select the firmware file from the local computer and wait for it to upload. Once it has finished uploading, it will appear in the Available Demodulator Versions list.

The screenshot displays the Adtec Digital Uploader interface. It features two main sections: 'Installed Firmware Versions' and 'Available Demodulator Firmware Versions'. Below these is a window titled 'Adtec Digital Uploader' showing a file upload progress.

Installed Firmware Versions

Versions	Update	Delete
Version 2.00.19 (***) current selection (***)	Restore	Current
Version 2.00.17	Select	Delete
Version 2.00.18	Select	Delete

Available Demodulator Firmware Versions

Versions	Update	Delete
Version RD_LB_DEMOD_v1	Select	Delete

Adtec Digital Uploader

Choose Files RD_LB_DEMO...c.fir.tgz Clear

Filename	Completed	%	Status
RD_LB_DEMOD_v1.20.adtec.i2c.fir.tgz	<div style="width: 100%;"></div>	100%	Complete

The time required to update firmware varies on hardware model and should be accounted for during the maintenance windows.

Estimated Time required to update firmware:
LB Demod firmware update - ~6 minutes

Once the version is seen on the Upgrade -> Firmware tab, click 'SELECT' to start the upgrade process. A status bar will appear and will progress as the firmware update commences. When the firmware update is complete, reboot the unit and verify the firmware version again on the Upgrade -> Features Tab.

Firmware		Features	
Installed Firmware Versions ⓘ			
Versions		Update	Delete
Version 1.01.04 (** current selection **)		Restore	Current
Active Demodulator Firmware Upgrade			
Start Time:	Thu Sep 4 12:12:39 2014		
			5.94% Completed

!!NOTE!! It is only recommended to update during a planned maintenance window. If a firmware upgrade fails for any reason, it is OK. Just try the upgrade again by clicking on the 'SELECT' button. The upgraded version can be verified by visiting the Upgrade -> Features tab after reboot. It is recommended to delete the file after a successful upgrade by clicking the 'DELETE' button.

In Field Feature Upgrades

Unit features can be upgraded in the field via the web user interface. Keys can either be temporary (feature will stop working after a set amount of time) or permanent (key is good for the life of the product). To purchase a permanent key, please provide the unit serial number and product ID from the Upgrade -> Features tab to your sales representative. If a temporary key is required, the Temporary ID will also be required.

Permanent Key Instructions

A permanent unlock key can be provided via email or verbally if internet access is not available. To enter the unlock key:

Step	Action
1	Click on the 'Input Key' button next to the desired feature.
2	Enter the supplied key into the pop-up dialog box and click OK.
3	The feature status should change from 'DISABLED' to 'ENABLED'.
4	In some cases, a reboot of the unit may be required after a state change to 'ENABLED'. Reboot unit if enabled feature does not function.

RD-71
Version 2.00.13
Temperature: 48(C)

Decoder Status:
Status: ● DECODING IP
Transmux Rate: 18500479 (b/s)
Service ID-Name: 3-EN-30 Servi...
Service Provider: Adtec Digital 1
Bars/Tones/ID: OFF/OFF/OFF
Decrypt Status: ● Free To Air

IP Rx Status:
Status: ● PLAYING
IP Addr./Port: 226.0.1.1/2000
Average Bitrate: 18500479 (b/s)
Buffer %/Level: 11% / 505 (ms)
Protocol: UDP

Video Status:
Video Rate: 13750372 (b/s)
CODEC/Chroma: H264 / 420
Bit Depth: 8
Format: 1920x1080 29.97i
SDIOUT Scale: 5D
SDIALT Scale: OFF
Video / PCR PID: 49 / 50

Audio Status:
A1: ● MPEG 1 Layer 2 / DECODE
PID: 51 / 192 (kb/s)
A2: ● MPEG 1 Layer 2 / DECODE
PID: 52 / 192 (kb/s)
A3: ● MPEG 1 Layer 2 / DECODE
PID: 53 / 192 (kb/s)
A4: ● MPEG 1 Layer 2 / DECODE
PID: 54 / 192 (kb/s)
A5: ○ --N/A--
A6: ○ --N/A--
A7: ○ --N/A--
A8: ○ --N/A--

Features
Serial: 201515224
Product ID: 01235C67CB2773AA
Temporary ID: 0000000XEBA187A6
Diagnostic Pkg.

BOARDS INFO

Slot	ID	Name
2	BI20	PCA111 ver 2.0

Name	Status	Expires	Action
PdRD71	ENABLED	NEVER	Input Key
1080P-DEC	ENABLED	NEVER	Input Key
AAC-AUD-DEC	ENABLED	NEVER	Input Key
SVC-FLTR	ENABLED	NEVER	Input Key

The page at 107.0.144.155:2222 says:
Please enter the KEY to enable/disable AUD-EXP
[Input Field]
OK Cancel

Temporary Key Instructions

If a temporary key is provided, it will be in the form of an email attachment or file. Temporary keys are *not* entered through the 'Input Key' button. Instead, they are transferred to the unit through the use of the file transfer utility via the 'Upload' button. The 'Upload' button is found in the top right hand corner of the Web UI.

Step	Action
1	Download the temporary key file to your computer provided by your representative.
2	Click on the 'Upload' button in the top right hand corner of the Web UI.
3	Browse for the supplied 'ASC' file from the file browser pop-up and click 'Open'
4	The page should reload and feature status should change from ' DISABLED ' to ' ENABLED ' with a 'Days Left' count. This count determines how many days the key will function before returning to a ' DISABLED ' state.
5	In some cases, a reboot of the unit may be required. Reboot unit if enabled feature does not function.

LOCKED
 rel: -48.2 dBm
 S2): 28.7 dB
 : 14.8 dB
 : 32APSK_3/4
 e: 1.144564 (Msym/s)
 : 1079.983 (MHz)
 ate: 4.153656 (Mb/s)

LOCKED
 rel: -40.9 dBm
 S2): 33.8 dB
 : 25.9 dB
 : 8PSK_3/4
 e: 29.89946 (Msym/s)
 : 1199.982 (MHz)
 ate: 65.090696 (Mb/s)

IDLE
 rt: 0.0.0.0/0
 rate: N/A
 level: N/A / 0 (ms)
 UDP
 ad: N/A
 N/A
 N/A

Slot	ID	Name
2	BI20	PCA111 ver 2.0

Name	Status	Expires	Action
PdRD70	ENABLED	NEVER	Input Key
AUD-EXP	ENABLED	NEVER	Input Key
DOLBY-DEC	ENABLED	NEVER	Input Key
MP4-CHR-422D	ENABLED	NEVER	Input Key
MP4-CHR-420D	ENABLED	NEVER	Input Key
MP2-BASE-D	ENABLED	NEVER	Input Key
10BIT-D	ENABLED	NEVER	Input Key
1080P-DEC	ENABLED	NEVER	Input Key
RD-LB-16APSK	ENABLED	NEVER	Input Key
RD-LB-32APSK	ENABLED	35 days	Input Key
RD-LB-65MSYM	ENABLED	NEVER	Input Key
AAC-AUD-DEC	DISABLED	0 days	Input Key

RD-71 Zixi Setup Guide

Where previous protocols, such as TCP, UDP and RTP have various constraints, Zixi is designed to overcome protocol limitations for broadcast quality video delivery. There are two Zixi options available on the RD-71, Zixi-Link and Zixi-Receive.

Zixi-Link is a point to point IP transport using Zixi technology to provide reliable video service over nondeterministic networks. If the IRD is behind a firewall, port forwarding is required. In this mode, Zixi parameters are configured on the sender (or Adtec encoder).

Zixi-Rx is used in point to multipoint applications and is combined with a Zixi Broadcaster server. In ZIXI-Rx mode, the IRD is acting as a client and can therefore bypass the need for firewall forwarding rules to the IRD. In this mode, all Zixi parameters are configured on the receiver (or RD-71).

Zixi uses a combination of FEC and ARQ to deliver packets. The amount of latency between end-points, the amount of packet loss incurred between end-points and the bandwidth requirements of the link all affect how the FEC and latency settings should be configured. These three items should be taken into consideration when doing initial setup.

Setting up Zixi-Link

To use Zixi-Link, the feature key must be enabled. This may be verified on the Upgrade -> Features tab.



If the key is not enabled please contact your sales representative, sales@adtecinc.com.

Select ZIXI-Link under IP Rx Mode.



The Web interface will prompt for a reboot confirmation, click Apply.

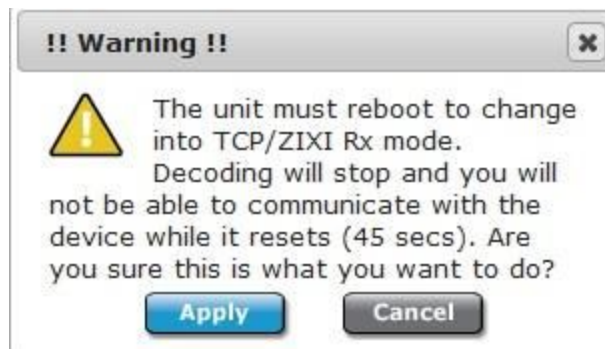

Once the unit is back up, select the correct Connector for the IP input, the default is IP2.

Connector: ? IP 2

As ZIXI-Link is a point to point transport input 0.0.0.0 into the Address field. Then input the correct port that the Zixi Feeder is set to. Default is 2088. Then click Apply.

Address: ? 0.0.0.0 Port: ? 2088

Via the Inpu -> RD Services tab, select the 'Select first found' radio button next to IP. If all settings are correct then the Zixi stream should appear and start decoding.

IP		Reset			Select first found	
Select	Service ID	Service Name	Service Provider	Details		
Current	3	EN200 Zixi-Link	Adtec Digital	Details		

Setting up Zixi Rx

To use Zixi-Rx, the feature key must be enabled. This may be verified on the Upgrade -> Features tab.

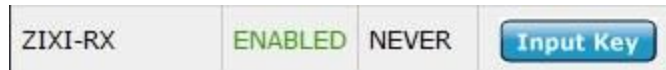

If the key is not enabled please contact your sales representative, sales@adtecinc.com.

Select ZIXI Rx under IP Rx Mode.

IP Rx Mode: ? ZIXI Rx

The Web interface will prompt for a reboot confirmation, click Apply.

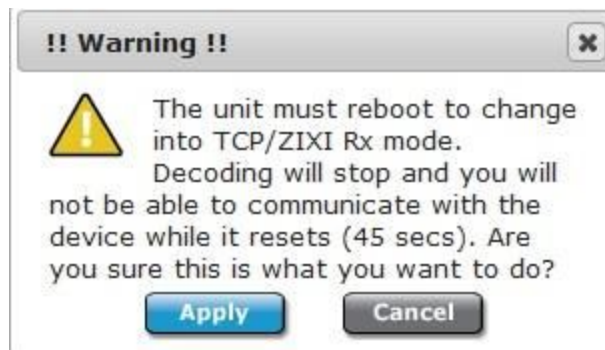

Once the unit is back up select the correct Connector for the IP input, default is IP2.

Connector: ? IP 2

Input the Zixi Broadcaster Address into the Address field, along with the Port in the Port box. The default port for the Zixi Broadcaster is 2077.

Address: Port:

Input the appropriate settings in the Zixi Receiver section (The channel name shall match the Broadcasters 'Stream ID' and Client ID should match the Broadcasters 'Remote ID').

Zixi Receiver (ZIXI Rx Mode Only): [?](#)

Channel Name: ?	<input type="text" value="en200nash"/>	Client ID: ?	<input type="text" value="ADTEC_CLIENT"/>
Session ID: ?	<input type="text"/>	Latency: ?	<input type="text" value="500"/>
FEC Enabled: ?	<input type="text" value="ENABLED"/>	FEC Content Aware: ?	<input type="text" value="DISABLED"/>
FEC Overhead (%): ?	<input type="text" value="20"/>	FEC Block (ms): ?	<input type="text" value="50"/>

Via the Input -> RD Services tab, select the 'Select first found' radio button next to IP. If all settings are correct then the Zixi stream should appear and start decoding.

IP		Reset			Select first found
Select	Service ID	Service Name	Service Provider	Details	
<input checked="" type="radio"/>	3	EN200 Zixi Rx	Adtec Digital	Details	

Appendix

Appendix A - GNU General Public License

Version 2, June 1991 Copyright (C) 1989, 1991 Free Software Foundation, Inc.

59 Temple Place, Suite 330, Boston, MA 02111-1307 USA

Everyone is permitted to copy and distribute verbatim copies of this license document, but changing it is not allowed.

Preamble

The licenses for most software are designed to take away your freedom to share and change it. By contrast, the GNU General Public License is intended to guarantee your freedom to share and change free software--to make sure the software is free for all its users. This General Public License applies to most of the Free Software Foundation's software and to any other program whose authors commit to using it. (Some other Free Software Foundation software is covered by the GNU Library General Public License instead.) You can apply it to your programs, too.

When we speak of free software, we are referring to freedom, not price. Our General Public Licenses are designed to make sure that you have the freedom to distribute copies of free software (and charge for this service if you wish), that you receive source code or can get it if you want it, that you can change the software or use pieces of it in new free programs; and that you know you can do these things.

To protect your rights, we need to make restrictions that forbid anyone to deny you these rights or to ask you to surrender the rights. These restrictions translate to certain responsibilities for you if you distribute copies of the software, or if you modify it.

For example, if you distribute copies of such a program, whether gratis or for a fee, you must give the recipients all the rights that you have. You must make sure that they, too, receive or can get the source code. And you must show them these terms so they know their rights.

We protect your rights with two steps: (1) copyright the software, and (2) offer you this license which gives you legal permission to copy, distribute and/or modify the software.

Also, for each author's protection and ours, we want to make certain that everyone understands that there is no warranty for this free software. If the software is modified by someone else and passed on, we want its recipients to know that what they have is not the original, so that any problems introduced by others will not reflect on the original authors' reputations.

Finally, any free program is threatened constantly by software patents. We wish to avoid the danger that redistributors of a free program will individually obtain patent licenses, in effect making the program proprietary. To prevent this, we have made it clear that any patent must be licensed for everyone's free use or not licensed at all.

The precise terms and conditions for copying, distribution and modification follow.

GNU GENERAL PUBLIC LICENSE TERMS AND CONDITIONS FOR COPYING, DISTRIBUTION AND MODIFICATION

0. This License applies to any program or other work which contains a notice placed by the copyright holder saying it may be distributed under the terms of this General Public License. The "Program", below, refers to any such program or work, and a "work based on the Program" means either the Program or any derivative work under copyright law: that is to say, a work containing the Program or a portion of it, either verbatim or with modifications and/or translated into another language. (Hereinafter, translation is included without limitation in the term "modification".) Each licensee is addressed as "you". Activities other than copying, distribution and modification are not covered by this License; they are outside its scope. The act of running the Program is not restricted, and the

output from the Program is covered only if its contents constitute a work based on the Program (independent of having been made by running the Program). Whether that is true depends on what the Program does.

1. You may copy and distribute verbatim copies of the Program's source code as you receive it, in any medium, provided that you conspicuously and appropriately publish on each copy an appropriate copyright notice and disclaimer of warranty; keep intact all the notices that refer to this License and to the absence of any warranty; and give any other recipients of the Program a copy of this License along with the Program. You may charge a fee for the physical act of transferring a copy, and you may at your option offer warranty protection in exchange for a fee.

2. You may modify your copy or copies of the Program or any portion of it, thus forming a work based on the Program, and copy and distribute such modifications or work under the terms of Section 1 above, provided that you also meet all of these conditions:

a) You must cause the modified files to carry prominent notices stating that you changed the files and the date of any change.

b) You must cause any work that you distribute or publish, that in whole or in part contains or is derived from the Program or any part thereof, to be licensed as a whole at no charge to all third parties under the terms of this License.

c) If the modified program normally reads commands interactively when run, you must cause it, when started running for such interactive use in the most ordinary way, to print or display an announcement including an appropriate copyright notice and a notice that there is no warranty (or else, saying that you provide a warranty) and that users may redistribute the program under these conditions, and telling the user how to view a copy of this License. (Exception: if the Program itself is interactive but does not normally print such an announcement, your work based on the Program is not required to print an announcement.)

These requirements apply to the modified work as a whole. If identifiable sections of that work are not derived from the Program, and can be reasonably considered independent and separate works in themselves, then this License, and its terms, do not apply to those sections when you distribute them as separate works. But when you distribute the same sections as part of a whole which is a work based on the Program, the distribution of the whole must be on the terms of this License, whose permissions for other licensees extend to the entire whole, and thus to each and every part regardless of who wrote it. Thus, it is not the intent of this section to claim rights or contest your rights to work written entirely by you; rather, the intent is to exercise the right to control the distribution of derivative or collective works based on the Program. In addition, mere aggregation of another work not based on the Program with the Program (or with a work based on the Program) on a volume of a storage or distribution medium does not bring the other work under the scope of this License.

3. You may copy and distribute the Program (or a work based on it, under Section 2) in object code or executable form under the terms of Sections 1 and 2 above provided that you also do one of the following:

a) Accompany it with the complete corresponding machine-readable source code, which must be distributed under the terms of Sections 1 and 2 above on a medium customarily used for software interchange; or,

b) Accompany it with a written offer, valid for at least three years, to give any third party, for a charge no more than your cost of physically performing source distribution, a complete machine-readable copy of the corresponding source code, to be distributed under the terms of Sections 1 and 2 above on a medium customarily used for software interchange; or,

c) Accompany it with the information you received as to the offer to distribute corresponding source code. (This alternative is allowed only for noncommercial distribution and only if you received the program in object code or executable form with such an offer, in accord with Subsection b above.)

The source code for a work means the preferred form of the work for making modifications to it. For an executable work, complete source code means all the source code for all modules it contains, plus any associated interface definition files, plus the scripts used to control compilation and installation of the executable. However, as a special exception, the source code distributed need not include anything that is normally distributed (in either source or binary form) with the major components (compiler, kernel, and so on) of the operating system on which the executable runs, unless that component itself accompanies the executable.

If distribution of executable or object code is made by offering access to copy from a designated place,

then offering equivalent access to copy the source code from the same place counts as distribution of the source code, even though third parties are not compelled to copy the source along with the object code.

4. You may not copy, modify, sublicense, or distribute the Program except as expressly provided under this License. Any attempt otherwise to copy, modify, sublicense or distribute the Program is void, and will automatically terminate your rights under this License. However, parties who have received copies, or rights, from you under this License will not have their licenses terminated so long as such parties remain in full compliance.

5. You are not required to accept this License, since you have not signed it. However, nothing else grants you permission to modify or distribute the Program or its derivative works. These actions are prohibited by law if you do not accept this License. Therefore, by modifying or distributing the Program (or any work based on the Program), you indicate your acceptance of this License to do so, and all its terms and conditions for copying, distributing or modifying the Program or works based on it.

6. Each time you redistribute the Program (or any work based on the Program), the recipient automatically receives a license from the original licensor to copy, distribute or modify the Program subject to these terms and conditions. You may not impose any further restrictions on the recipients' exercise of the rights granted herein. You are not responsible for enforcing compliance by third parties to this License.

7. If, as a consequence of a court judgment or allegation of patent infringement or for any other reason (not limited to patent issues), conditions are imposed on you (whether by court order, agreement or otherwise) that contradict the conditions of this License, they do not excuse you from the conditions of this License. If you cannot distribute so as to satisfy simultaneously your obligations under this License and any other pertinent obligations, then as a consequence you may not distribute the Program at all. For example, if a patent license would not permit royalty-free redistribution of the Program by all those who receive copies directly or indirectly through you, then the only way you could satisfy both it and this License would be to refrain entirely from distribution of the Program. If any portion of this section is held invalid or unenforceable under any particular circumstance, the balance of the section is intended to apply and the section as a whole is intended to apply in other circumstances. It is not the purpose of this section to induce you to infringe any patents or other property right claims or to contest validity of any such claims; this section has the sole purpose of protecting the integrity of the free software distribution system, which is implemented by public license practices. Many people have made generous contributions to the wide range of software distributed through that system in reliance on consistent application of that system; it is up to the author/donor to decide if he or she is willing to distribute software through any other system and a licensee cannot impose that choice. This section is intended to make thoroughly clear what is believed to be a consequence of the rest of this License.

8. If the distribution and/or use of the Program is restricted in certain countries either by patents or by copyrighted interfaces, the original copyright holder who places the Program under this License may add an explicit geographical distribution limitation excluding those countries, so that distribution is permitted only in or among countries not thus excluded. In such case, this License incorporates the limitation as if written in the body of this License.

9. The Free Software Foundation may publish revised and/or new versions of the General Public License from time to time. Such new versions will be similar in spirit to the present version, but may differ in detail to address new problems or concerns. Each version is given a distinguishing version number. If the Program specifies a version number of this License which applies to it and "any later version", you have the option of following the terms and conditions either of that version or of any later version published by the Free Software Foundation. If the Program does not specify a version number of this License, you may choose any version ever published by the Free Software Foundation.

10. If you wish to incorporate parts of the Program into other free programs whose distribution conditions are different, write to the author to ask for permission. For software which is copyrighted by the Free Software Foundation, write to the Free Software Foundation; we sometimes make exceptions for this. Our decision will be guided by the two goals of preserving the free status of all derivatives of our free software and of promoting the sharing and reuse of software generally.

NO WARRANTY

11. BECAUSE THE PROGRAM IS LICENSED FREE OF CHARGE, THERE IS NO WARRANTY FOR THE PROGRAM, TO

THE EXTENT PERMITTED BY APPLICABLE LAW. EXCEPT WHEN OTHERWISE STATED IN WRITING THE COPYRIGHT HOLDERS AND/OR OTHER PARTIES PROVIDE THE PROGRAM "AS IS" WITHOUT WARRANTY OF ANY KIND, EITHER EXPRESSED OR IMPLIED, INCLUDING, BUT NOT LIMITED TO, THE IMPLIED WARRANTIES OF MERCHANTABILITY AND FITNESS FOR A PARTICULAR PURPOSE. THE ENTIRE RISK AS TO THE QUALITY AND PERFORMANCE OF THE PROGRAM IS WITH YOU. SHOULD THE PROGRAM PROVE DEFECTIVE, YOU ASSUME THE COST OF ALL NECESSARY SERVICING, REPAIR OR CORRECTION.

12. IN NO EVENT UNLESS REQUIRED BY APPLICABLE LAW OR AGREED TO IN WRITING WILL ANY COPYRIGHT HOLDER, OR ANY OTHER PARTY WHO MAY MODIFY AND/OR REDISTRIBUTE THE PROGRAM AS PERMITTED ABOVE, BE LIABLE TO YOU FOR DAMAGES, INCLUDING ANY GENERAL, SPECIAL, INCIDENTAL OR CONSEQUENTIAL DAMAGES ARISING OUT OF THE USE OR INABILITY TO USE THE PROGRAM (INCLUDING BUT NOT LIMITED TO LOSS OF DATA OR DATA BEING RENDERED INACCURATE OR LOSSES SUSTAINED BY YOU OR THIRD PARTIES OR A FAILURE OF THE PROGRAM TO OPERATE WITH ANY OTHER PROGRAMS), EVEN IF SUCH HOLDER OR OTHER PARTY HAS BEEN ADVISED OF THE POSSIBILITY OF SUCH DAMAGES.

END OF TERMS AND CONDITIONS

How to Apply These Terms to Your New Programs

If you develop a new program, and you want it to be of the greatest possible use to the public, the best way to achieve this is to make it free software which everyone can redistribute and change under these terms.

To do so, attach the following notices to the program. It is safest to attach them to the start of each source file to most effectively convey the exclusion of warranty; and each file should have at least the "copyright" line and a pointer to where the full notice is found.

<one line to give the program's name and a brief idea of what it does.> Copyright (C) <year> <name of author>
This program is free software; you can redistribute it and/or modify it under the terms of the GNU General Public License as published by the Free Software Foundation; either version 2 of the License, or (at your option) any later version.

This program is distributed in the hope that it will be useful, but WITHOUT ANY WARRANTY; without even the implied warranty of MERCHANTABILITY or FITNESS FOR A PARTICULAR PURPOSE. See the GNU General Public License for more details.

You should have received a copy of the GNU General Public License along with this program; if not, write to the Free Software Foundation, Inc., 59 Temple Place, Suite 330, Boston, MA 02111-1307 USA

Also add information on how to contact you by electronic and paper mail.

If the program is interactive, make it output a short notice like this when it starts in an interactive mode:

Gnomovision version 69, Copyright (C) year name of author Gnomovision comes with ABSOLUTELY NO WARRANTY; for details type `show w'. This is free software, and you are welcome to redistribute it under certain conditions; type `show c' for details.

The hypothetical commands `show w' and `show c' should show the appropriate parts of the General Public License. Of course, the commands you use may be called something other than `show w' and `show c'; they could even be mouse-clicks or menu items--whatever suits your program.

You should also get your employer (if you work as a programmer) or your school, if any, to sign a "copyright disclaimer" for the program, if necessary. Here is a sample; alter the names:

Yoyodyne, Inc., hereby disclaims all copyright interest in the program `Gnomovision' (which makes passes at compilers) written by James Hacker. <signature of Ty Coon>, 1 April 1989 Ty Coon, President of Vice

This General Public License does not permit incorporating your program into proprietary programs. If your program is a subroutine library, you may consider it more useful to permit linking proprietary applications with the library. If this is what you want to do, use the GNU Library General Public License instead of this License.

Appendix B - Technical Specifications

Base Model (RD71-XX)

Inputs

DVB-ASI

Use: Input available for Decode or Pass to ASI outputs.

Standard: Asynchronous Serial Interface per EN500083-9

Input Rates: DVB-ASI 210Mb/s for free-to-air 188/204/208 Byte Transport streams (SPTS and MPTS).

Connector: BNC (75 Ohm)

IP

Use: Input can receive streams via the IP 1 or IP 2 port.

Standard: MPEG 2 RTP v2 (RFC 3550), SMPTE 2022-1 2007 FEC, MPEG 2 UDP, TCP and Zixi transport

Connection speed: GigE (10/100/1000BaseT)

Connector: 2x RJ45

DVB-S/S2/S2X L-Band Demodulator (optional)

Use: L-Band input available for decode, see LB and PRX option specifications.

Standard: DVB-S, DVB-S2 & DVB-S2X QPSK/8PSK/16APSK/32APSK/64APSK options available

Connector: Two Female F connectors (75 Ohm LB model), Four Female F connectors (75 Ohm PRX model)

Sync Input

Use: Auto-detects Bi-Level and Tri-level sync for Genlock, 3D and Ultra HD applications.

Connector: BNC (75 Ohm)

Outputs

3G-SDI / HD-SDI / SD-SDI

Two banks (two mirrored SDI outputs per bank) of SDI Outputs from Decoder

Standard: Video & Audio SMPTE 259M - SD, SMPTE 292M - HD, SMPTE 424M - 3G

Up to 16 Channels of Embedded audio

SDI Ancillary support for Closed Captioning, AFD and Teletext

SDI Ancillary data and OSD overlay have unique configuration for each SDI bank

Connector: Three BNC (75 Ohm), One SFP

note*: 3G-SDI Outputs have selectable Level A and Level B Dual Link output control to retain interoperability with other third party 3G devices. The default mapping level is level A. Unit has ability to output HD and SD simultaneously via downscaling on one bank.

CVBS

SD NTSC or PAL D1 Composite Video Output (downscaled from HD source)

Supports Closed Captioning and Teletext

Connector: BNC (75 Ohm)

DVB-ASI

Standard: Asynchronous Serial Interface per EN500083-9

ASI Mirrored from DVB-ASI Input, IP Input, or RF Input with purchase of optional tuner package. All streams are output as 188 byte packets.

Connector: 3x BNC (75 Ohm)

AES Audio

Standard: AES3

8 pairs of decoded audio

Connector: 8x BNC (75 Ohm)

Analog Audio

Two balanced pairs via DB9 connector. (1 pair per DB9)

+18dBu nominal clipping level, -40 to +18dBu selectable.

Connector: 2x DB9 (600 Ohm)

IP Output

Use: Output available for unicast/multicast transmit. TS input/output can share the same connector as required.

Standard: UDP, RTP and SMPTE 2022 COP3 FEC

Supports 1 to 7 TS packets per IP packet

Connection speed: GigE (10/100/1000 Auto-Negotiate)

Transmit capability: x4 simultaneous MPEG over IP transport streams

Connector: 2x RJ45

Communications

COM2 Serial Port

Use: API Serial Communication Interface

Default Baud Configuration: 38,400bps 8 data bits 1 stop bit no parity

Connector: 8 pin RJ45

COM1 Serial Port

Use: Serial Port Used for Troubleshooting (Terminal)

Connector: 8 pin RJ45 (supplied with DB9 to RJ45 adapter)

Baud Configuration: 115,200 bps 8 data bits 1 stop bit no parity

IP 1 and IP 2 GigE Ports

Use: IP 1 port is used for network management by default, but can also be used for IP receive. IP 2 port can also be used for management. Security controls allow disabling IP 2 management as needed.

Format: GigE 10/100/1000BaseT

Communication Methods: WebUI, SNMP, Telnet, XCP

Connector: 2x RJ45

DB9 Parallel Port

Use: DB9 parallel port used for custom triggering / integration

Connector: DB9 Male

GPIO Port

Use: not used as this time

Connector: DB9 Male

Video and Audio

Video Decode

MPEG-2 SD (ISO/IEC 13818-2) Decode:

Format: 480i59.94, 576i50

Profiles: MP@ML, SP@ML, 422P@ML

MPEG-2 HD (ISO/IEC 13818-2) Decode:

Format: 720p50, 720p59.94, 1080i50, 1080i59.94

Profiles: 422P@HL, MP@H14L, MP@HL, SP@H14L, SP@HL

MPEG-4 SD (ISO/IEC 14496-10) Decode:

Format: 480i59.94, 576i50

Profiles: Baseline, Main (support 8 bits only)

MPEG-4 HD (ISO/IEC 14496-10) Decode:

Format: 720p50, 720p59.94, 1080i50, 1080i59.94, 1080p50, 1080p59.94, 1080p25, 1080p29.97

Profiles: High, High422 (support 8 bit and 10 bit)

Max Level: 4.1-4.2 (CABAC:50Mb/s, CAVLC:150Mb/s)

Supported tools support Baseline except ASO, FMO

Audio Decode

MPEG 1 Layer 2 audio (8 pairs)

Dolby Digital AC3 stereo downmix (8 pairs) *requires feature key

AAC-LC stereo *requires feature key

AAC 6.0 Surround Decode (AAC-LC) *requires feature key

Audio Pass-through

Supports up to two Dolby-E 16/20 bit, Dolby Digital AC3 16 bit, and/or Linear PCM 16/20/24 bit pass-through sessions. 24 bit input samples are truncated to 20 bits. Each SDI output contains all active pass-through sessions.

Physical and Operational

Physical / Environmental

Weight – 9-10.15lbs. Dependent on RF option

Power

Input Voltage: 100VAC - 240VAC 50/60Hz. Wattage dependent on RF option

Startup - 35W, Operational 36W

PRX Option: Startup - 46W, Operational 46W

LB Option: Startup - 35W, Operational 37W

Certification / Compliance

RoHS Compliant

L-Band Demodulator (LB option)

note: Software keys are required to unlock full hardware support.

RF Inputs: Dual RF inputs capable of simultaneous lock

EN 302 207 and EN 300 421 compliant for single and multi-stream

Modulation Scheme support: QPSK / 8PSK / 16APSK / 32APSK

Long and Short frame support

Physical Layer Scrambling, PLS, Gold Code support (CODE0, CODE1 and CODE2)

Multi-stream ISI support

CCM - VCM/ACM support

Supported Roll-off: 5%, 10%, 15%, 20%, 25%, 35%

Supported Code Rates:

DVB-S QPSK: 1/2, 3/5, 2/3, 3/4, 5/6, 7/8

DVB-S2 QPSK: 1/4, 1/3, 2/5, 1/2, 3/5, 2/3, 3/4, 4/5, 5/6, 8/9, 9/10

DVB-S2 8PSK: 3/5, 2/3, 3/4, 5/6, 8/9, 9/10

DVB-S2 16APSK: 2/3, 3/4, 4/5, 5/6, 8/9, 9/10

DVB-S2 32APSK: 3/4, 4/5, 5/6, 8/9, 9/10

DVB-S symbol rate range: Up to 62Msym/s*

DVB-S2 symbol rate range: 1 - 65Msym/s (QPSK / 8PSK / 16APSK / 32APSK)*

frequency range: 950 - 2150MHz

min. input level: -65dBm**

max. input level: -25dBm**

LNB Power and Control:

13V (vertical polarisation)

18V (horizontal polarisation)

22kHz (band selection according to universal LNB for ASTRA satellites)

**input level dependent on function of MODCOD and baudrate

* Maximum supported baud rate is dependent on both tuners active state. One must be disabled to achieve maximum symbol rate capabilities. View table below for symbol rate capabilities.

Modulation	Single Tuner (Msym/s)	Dual Tuner (Msym/s)
QPSK	65	65
8PSK	65	45
16APSK	65	33
32APSK	54	27

DVB-S2X L-Band Demodulator (PRX option)

note: Software keys are required to unlock full hardware support.

RF Inputs: Quad RF inputs (1 selectable)

DVB-S/DSNG: EN 300 421 and EN 301 210

DVB-S2(X): EN 302 307 and DVB Document A83-2 (excluding VL-SNR)

Modulation Scheme support: QPSK / 8PSK / 16APSK / 32APSK / 64APSK

Long and Short frame support

Physical Layer Scrambling, PLS, Gold Code support

Multistream ISI Support

Supported Roll-off: 5%, 10%, 15%, 20%, 25%, 35%

Supported Code Rates:

DVB-S/DSNG QPSK: 1/2, 3/5, 2/3, 3/4, 5/6, 7/8

DVB-S/DSNG 8PSK: 2/3, 5/6, 8/9

DVB-S/DSNG 16QAM: 3/4, 7/8

DVB-S2 QPSK: 1/4, 1/3, 2/5, 1/2, 3/5, 2/3, 3/4, 4/5, 5/6, 8/9, 9/10

DVB-S2 8PSK: 3/5, 2/3, 3/4, 5/6, 8/9, 9/10

DVB-S2 16APSK: 2/3, 3/4, 4/5, 5/6, 8/9, 9/10

DVB-S2 32APSK: 3/4, 4/5, 5/6, 8/9, 9/10

DVB-S2X QPSK: 13/45, 9/20, 11/20, 11/45, 4/15, 14/45, 7/15, 8/15, 32/45

DVB-S2X 8APSK: 4/9-L, 26/45-L

DVB-S2X 8PSK: 23/36, 25/36, 13/18, 7/15, 8/15, 26/45, 32/45

DVB-S2X 16APSK: 1/2-L, 8/15-L, 5/9-L, 26/45, 3/5, 3/5-L, 28/45, 23/36, 2/3-L, 25/36, 13/18, 7/9, 77/90, 7/15, 8/15, 26/45, 3/5, 32/45

DVB-S2X 32APSK: 2/3-L, 32/45, 11/15, 7/9, 2/3, 32/45

DVB-S2X 64APSK: 32/45-L, 11/15, 7/9, 4/5, 5/6

DVB-S symbol rate range: 1 - 45Msym/s

DVB-S2(X) symbol rate range: 1 - 60Msym/s (QPSK / 8PSK / 16APSK / 32APSK / 64APSK)*

frequency range: 950 - 2150MHz

max. carrier level: -25dBm**

Carrier acquisition Range: up to 7.5MHz

DVB-S/DSNG

(if symbolrate < 7 Mbaud:
symbolrate/10 + user range.

if symbolrate > 7 Mbaud:
7.5MHz + symbolrate/10)

DVB-S2(X)

(if symbolrate < 20 Mbaud:
range: symbolrate/2 to symbolrate * 1.1

if symbolrate > 20 Mbaud:
range: (1+roll-off) * symbolrate/2

Return loss: >11dB

Isolation between inputs: >40dB

LNB Power and Control:

11.5 - 15V (vertical polarisation)

16 - 19V (horizontal polarisation)

22kHz +/- 4kHz (band selection according to universal LNB for ASTRA satellites)

**input level dependent on function of baudrate

Appendix C - Adtec Digital Support & Service

For Customer Service contact information, SLA Information, policies and more, please visit the support site at: <http://www.adtecdigital.com/support> .

Appendix D - Electrical Device Compliance Notices

Safety Warnings and Cautions

For your safety and the proper operation of the device:

- This unit must be installed and serviced by suitably qualified personnel only.
- Do not break the warranty seals on the device or open the lid. Only approved service technicians are permitted to service this equipment.
- Disconnect all power before servicing the unit.
- Do not expose this device to rain or other moisture. Clean only with a dry cloth.
- If not installed in an equipment rack, install the product securely on a stable surface.
- Install the product in a protected location where no one can step or trip over the supply cord, and where the supply cord will not be damaged.
- If a system is installed in a closed or multi-unit rack assembly, the operating ambient temperature of the rack environment may be greater than the room ambient temperature.
- Consideration should be given to installing the unit in an environment compatible with the maximum recommended ambient temperature of 50 degrees Celsius (122 degrees Fahrenheit).
- Install the unit in a rack so that the amount of airflow required for safe operation is not compromised.
 - The recommended clearance on the top and sides of the unit is at least ½ " (one half inch/one centimeter).
- Mounting of the unit in a rack should be such that no hazardous condition is achieved due to uneven mechanical loading.
- Use only a grounded electrical outlet when connecting the unit to a power source.
- Reliable earth grounding of rack-mount equipment should be maintained.
 - Particular attention should be given to supply connection other than direct connections to the branch circuit (e.g., use of power strips).

Compliance Notices

FCC

Note: This equipment has been tested and found to comply with the limits for a Class B digital device, pursuant to Part 15 of the FCC Rules. These limits are designed to provide reasonable protection against harmful interference in a residential installation. This equipment generates, uses and can radiate radio frequency energy and, if not installed and used in accordance with the instructions, may cause harmful interference to radio communications. However, there is no guarantee that interference will not occur in a particular installation. If this equipment does cause harmful interference to radio or television reception, which can be determined by turning the equipment off and on, the user is encouraged to try to correct the interference by one or more of the following measures:

- Reorient or relocate the receiving antenna.
- Increase the separation between the equipment and receiver.

- Connect the equipment into an outlet on a circuit different from that to which the receiver is connected.
- Consult the dealer or an experienced radio/TV technician for help.

Warning: Changes or modifications to this device not expressly approved by Adtec Digital could void the user's authority to operate the equipment.

Industry Canada

This Class B digital apparatus meets all requirements of the Canadian Interference Causing Equipment Regulations. Operation is subject to the following two conditions: (1) this device may not cause harmful interference, and (2) this device must accept any interference received, including interference that may cause undesired operation.

Cet appareillage numérique de la classe B répond à toutes les exigences de l'interférence canadienne causant des règlements d'équipement. L'opération est sujette aux deux conditions suivantes: (1) ce dispositif peut ne pas causer l'interférence nocive, et (2) ce dispositif doit accepter n'importe quelle interférence reçue, y compris l'interférence qui peut causer l'opération peu désirée.

European Union EMC Directive Conformance Statement

This product is in conformity with the protection requirements of EU Council Directive 2004/108/EC on the approximation of the laws of the Member States relating to electromagnetic compatibility. Adtec Digital cannot accept responsibility for any failure to satisfy the protection requirements resulting from a user modification of the product. This product has been tested and found to comply with the limits for Class B Information Technology Equipment according to CISPR 22 / EN 55022.

Trademarks & Copyrights

Copyright: (c) 2011-15 Adtec Digital. All rights reserved. This document may not, in whole or in part, be copied, photocopied, reproduced and translated, or reduced to any electronic medium or machine-readable form without prior written consent from Adtec Digital.

Trademarks: RD-71 is a trademark of Adtec Digital. Dolby, Dolby Digital, AC-3 and the double-D symbol are registered trademarks of Dolby Laboratories. Other product and company names may be trademarks or registered trademarks of their respective companies. The information in this document is subject to change without notice.